

# Post & Rail Kit - 80321

# mimSAFE

[mimclip.mimsafe.com](http://mimclip.mimsafe.com)

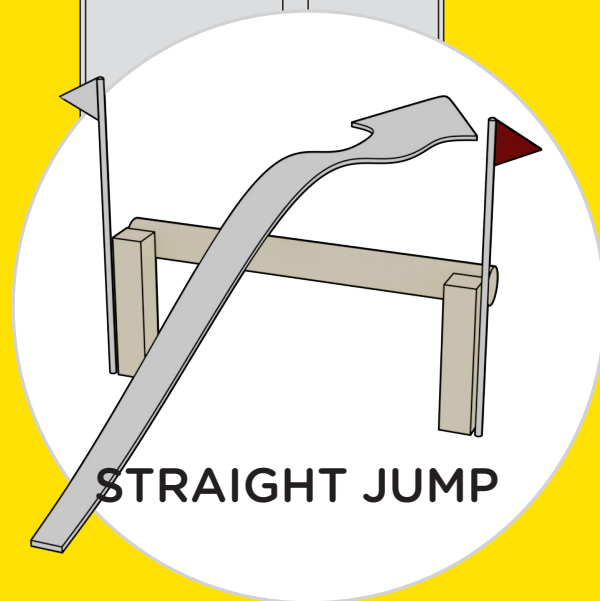

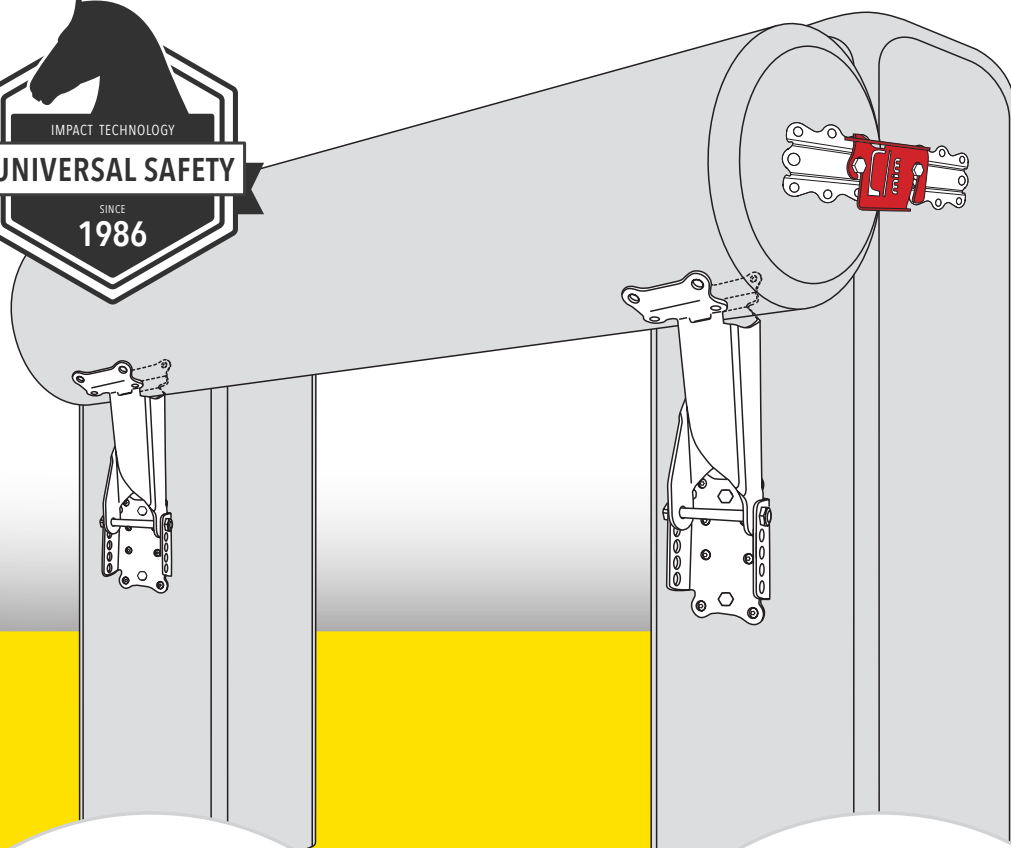





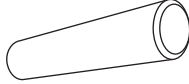

# INFORMATION ABOUT THE POST & RAIL KIT

The Post & Rail Kit has been designed and developed specifically to greatly reduce the risk of rotational falls. The most important element of this kit is that it will not

break the fence or risk injury to the horse if hit vertically. The rail is only released when impacted horizontally by the horse. The risk of a resulting rotational fall is thus reduced.

## FENCE DIMENSIONS

POST	TOP SECTION STRAIGHT JUMP	TOP SECTION STRAIGHT HEAVY JUMP	TOP SECTION ANGLED JUMP																
																			
<b>MIN-MAX SIZE</b>	<b>MIN-MAX DIAMETER</b>	<b>MIN-MAX DIAMETER</b>	<b>MIN-MAX DIAMETER</b>																
<table border="1"> <tr> <td>6 - 10</td> <td>inch</td> </tr> <tr> <td>150 - 250</td> <td>mm</td> </tr> </table>	6 - 10	inch	150 - 250	mm	<table border="1"> <tr> <td>8 - 12</td> <td>inch</td> </tr> <tr> <td>200 - 300</td> <td>mm</td> </tr> </table>	8 - 12	inch	200 - 300	mm	<table border="1"> <tr> <td>8 - 12</td> <td>inch</td> </tr> <tr> <td>200 - 300</td> <td>mm</td> </tr> </table>	8 - 12	inch	200 - 300	mm	<table border="1"> <tr> <td>8 - 12</td> <td>inch</td> </tr> <tr> <td>200 - 300</td> <td>mm</td> </tr> </table>	8 - 12	inch	200 - 300	mm
6 - 10	inch																		
150 - 250	mm																		
8 - 12	inch																		
200 - 300	mm																		
8 - 12	inch																		
200 - 300	mm																		
8 - 12	inch																		
200 - 300	mm																		
	<b>MAXIMUM LENGTH</b>	<b>MAXIMUM LENGTH</b>	<b>MAXIMUM LENGTH</b>																
<table border="1"> <tr> <td>6 - 10</td> <td>inch</td> </tr> <tr> <td>150 - 250</td> <td>mm</td> </tr> </table>	6 - 10	inch	150 - 250	mm	<table border="1"> <tr> <td>13.1</td> <td>ft</td> </tr> <tr> <td>4000</td> <td>mm</td> </tr> </table>	13.1	ft	4000	mm	<table border="1"> <tr> <td>13.1</td> <td>ft</td> </tr> <tr> <td>4000</td> <td>mm</td> </tr> </table>	13.1	ft	4000	mm	<table border="1"> <tr> <td>13.1</td> <td>ft</td> </tr> <tr> <td>4000</td> <td>mm</td> </tr> </table>	13.1	ft	4000	mm
6 - 10	inch																		
150 - 250	mm																		
13.1	ft																		
4000	mm																		
13.1	ft																		
4000	mm																		
13.1	ft																		
4000	mm																		
<b>MIN-MAX WEIGHT WITH RED CLIP</b>	<b>MIN-MAX WEIGHT WITH RED CLIP</b>	<b>MIN-MAX WEIGHT WITH YELLOW CLIP</b>	<b>MIN-MAX WEIGHT WITH YELLOW CLIP</b>																
<table border="1"> <tr> <td>110 - 265</td> <td>lb</td> </tr> <tr> <td>50 - 120</td> <td>kg</td> </tr> </table>	110 - 265	lb	50 - 120	kg	<table border="1"> <tr> <td>110 - 265</td> <td>lb</td> </tr> <tr> <td>50 - 120</td> <td>kg</td> </tr> </table>	110 - 265	lb	50 - 120	kg	<table border="1"> <tr> <td>265 - 395</td> <td>lb</td> </tr> <tr> <td>120 - 180</td> <td>kg</td> </tr> </table>	265 - 395	lb	120 - 180	kg	<table border="1"> <tr> <td>200 - 265</td> <td>lb</td> </tr> <tr> <td>90 - 120</td> <td>kg</td> </tr> </table>	200 - 265	lb	90 - 120	kg
110 - 265	lb																		
50 - 120	kg																		
110 - 265	lb																		
50 - 120	kg																		
265 - 395	lb																		
120 - 180	kg																		
200 - 265	lb																		
90 - 120	kg																		
																			
(Yellow clips not included in this assembly kit) order yellow clip spare parts																			

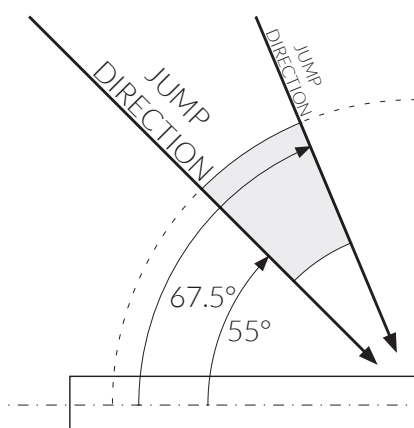

All the dimensions have been tested and are in concordance to the approved tests.

Angled fence tests have been performed with a jumping angle between 55 - 67.5 degrees.



It is essential to follow the recommended dimensions on the fence for the correct function. If the recommended procedure is not correctly followed it may cause the failure of the device.

For your own safety and that of others please note the following step by step advice for correct preparation and installation. It is important that you follow your own health and safety requirements when constructing this kit.

**Ensure that you have all parts of the Post & Rail Narrow Kit.**  
**Be aware of the risk of injury when handling heavy rails, posts and the tools for mounting.**

**WARNING!**

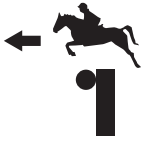

Jumping direction

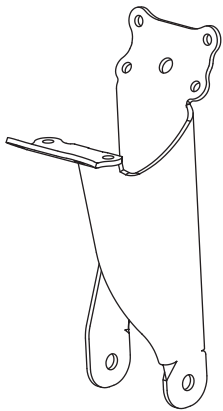
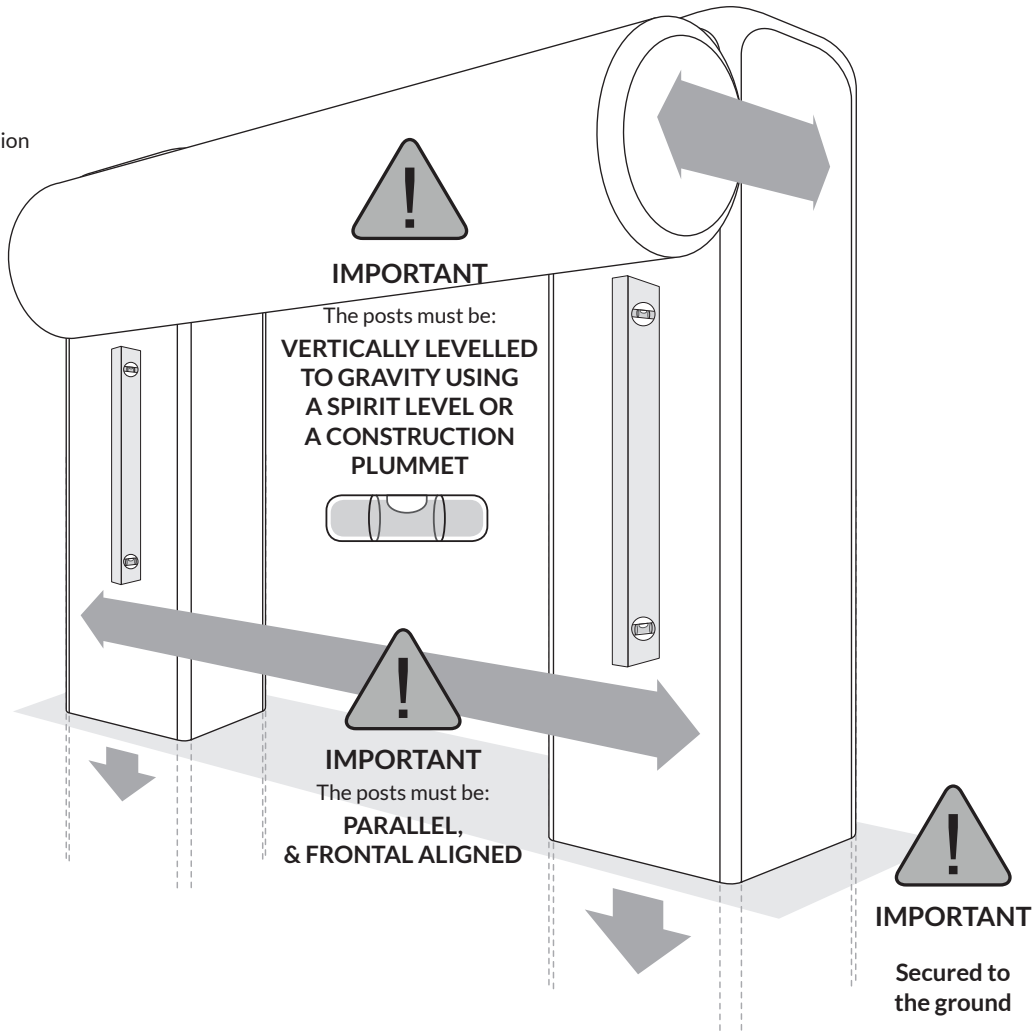

**A** F65 2x  
Part no

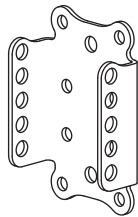

**B** F64A5 2x  
Part no

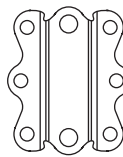

**C** F70A 4x  
Part no



**D** F18C 6x  
Part no





**E** F18F 6x  
Part no

<p>M-SM12x120 2X</p>	<p>M-BR12x22x2s 2X</p>	<p>M-MM12Ny 2X</p>	<p>M-TS10X90 4X</p>	<p>POST 2X</p> <p>not included</p>	<p>RAIL 1X</p> <p>not included</p>
--------------------------	----------------------------	------------------------	-------------------------	--	--

STEP  
**1**

**2X**

M-SM12x120 2X 	M-BR12x22x2s 2X 	M-MM12Ny 2X 
---	---	---

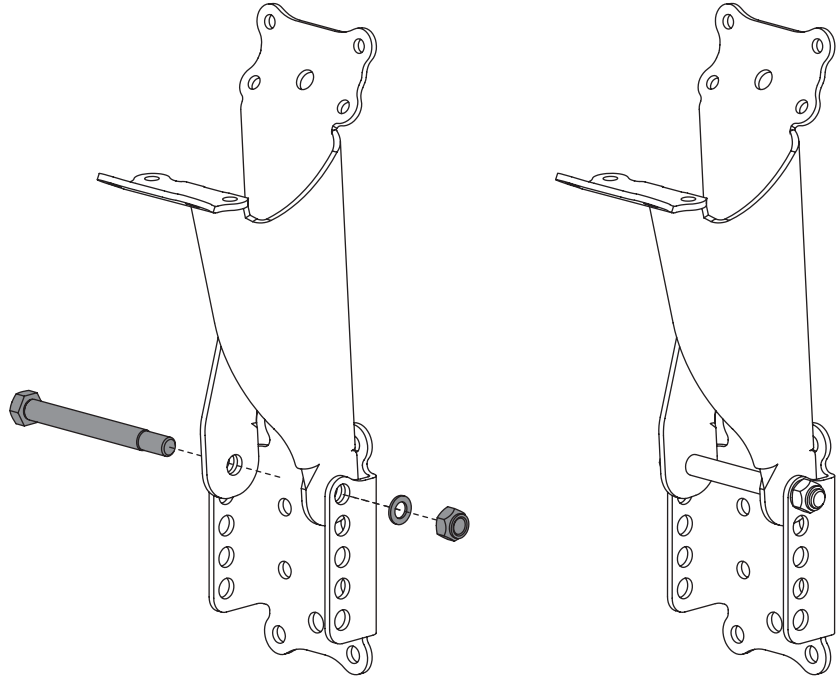
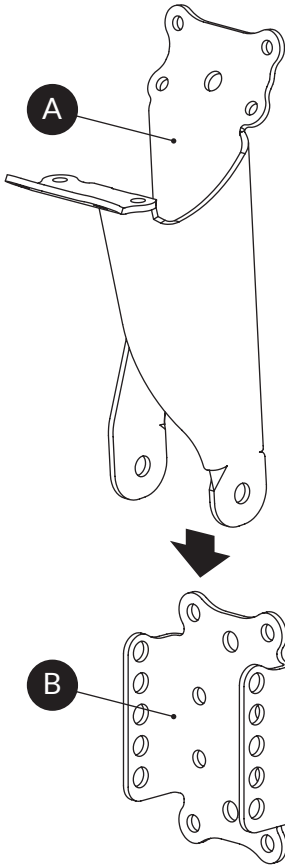

STEP  
**2**

**2X**

**ADJUST TO  
CORRECT HEIGHT**

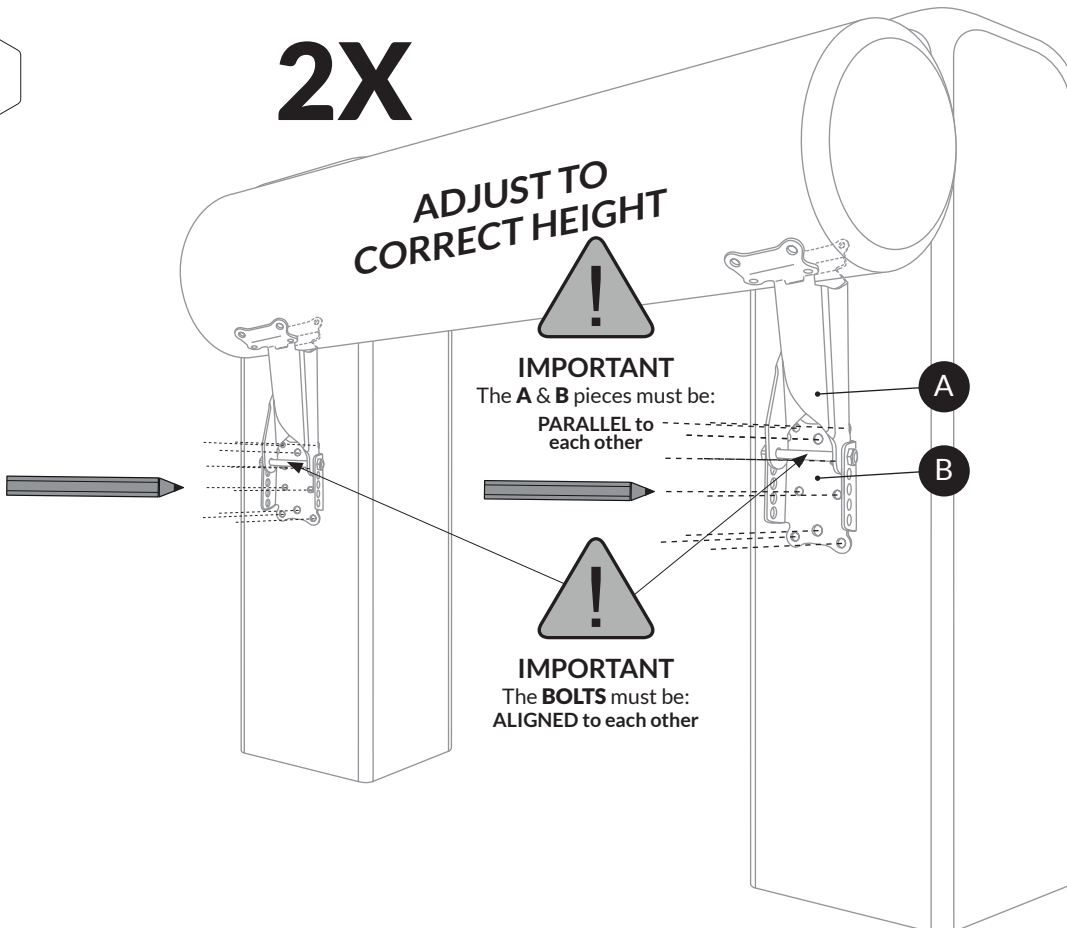

**IMPORTANT**  
The **A & B** pieces must be:  
**PARALLEL** to  
each other



**IMPORTANT**  
The **BOLTS** must be:  
**ALIGNED** to each other

STEP  
**3**

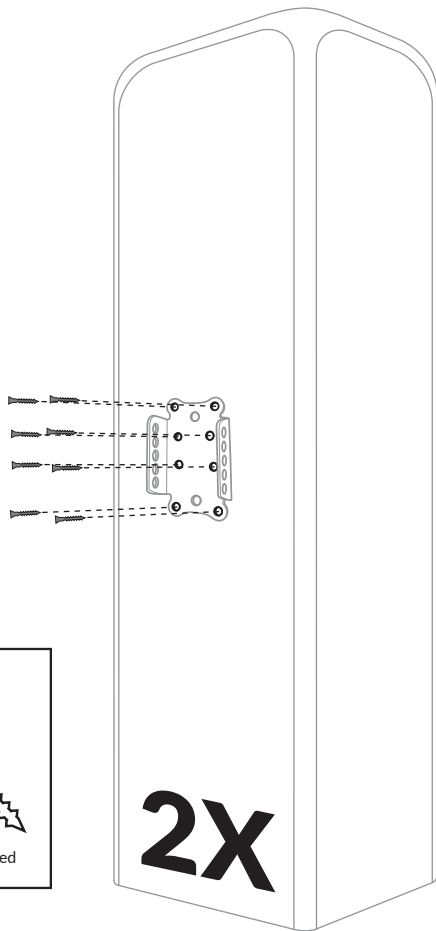

STEP  
**3\***

\*alternative

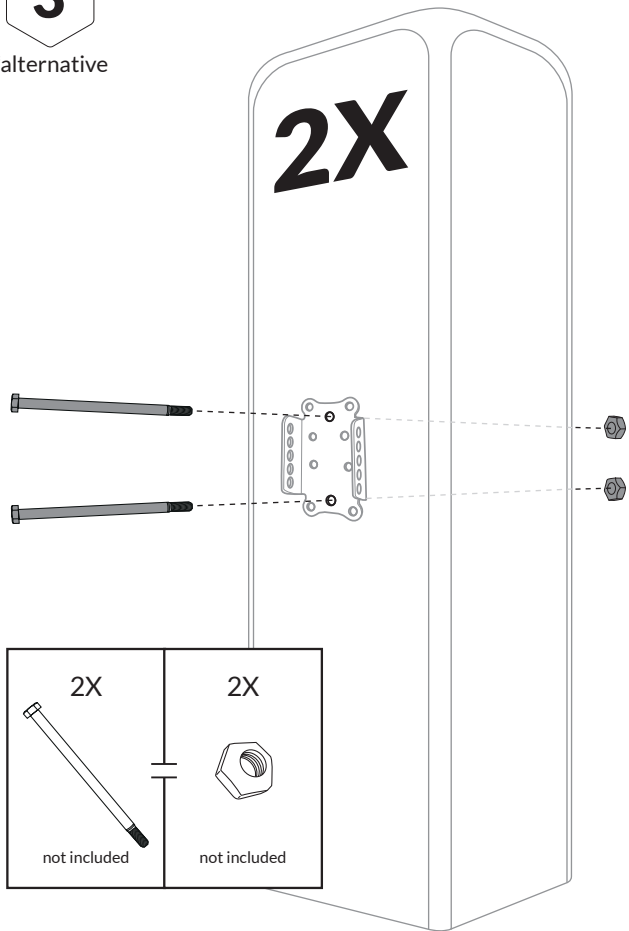

STEP  
**4**

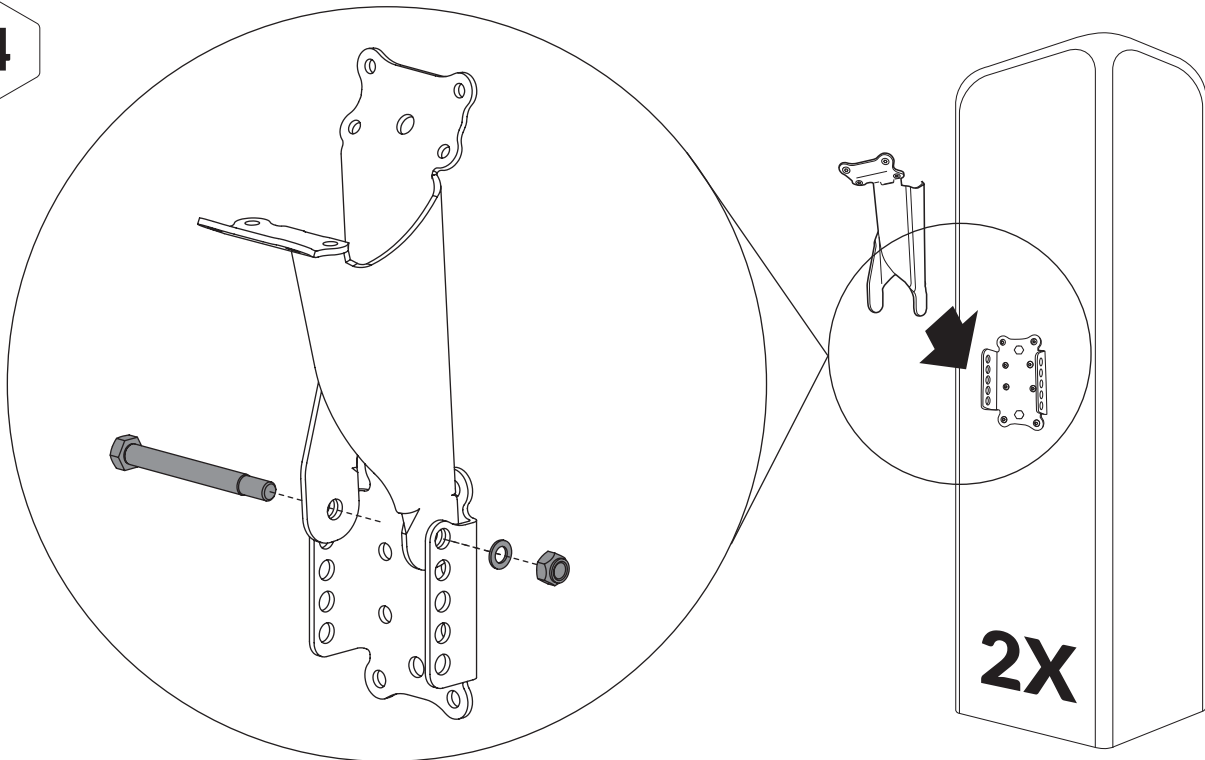

STEP  
**5**

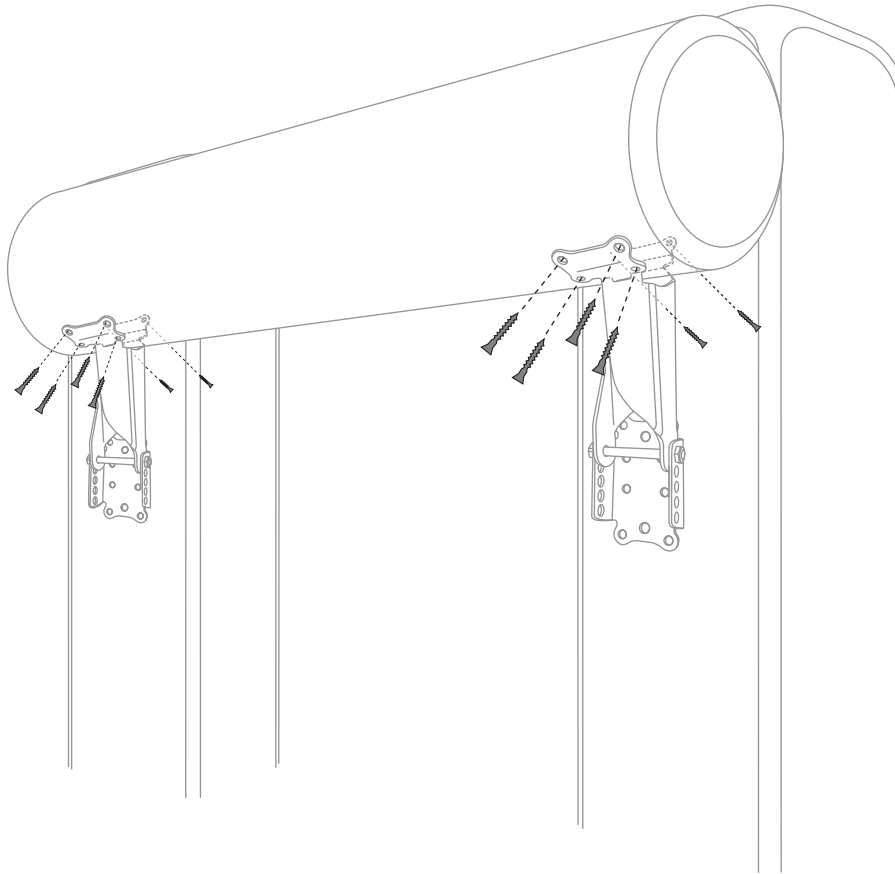

12X

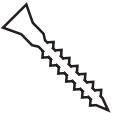



not included

STEP  
**5\***

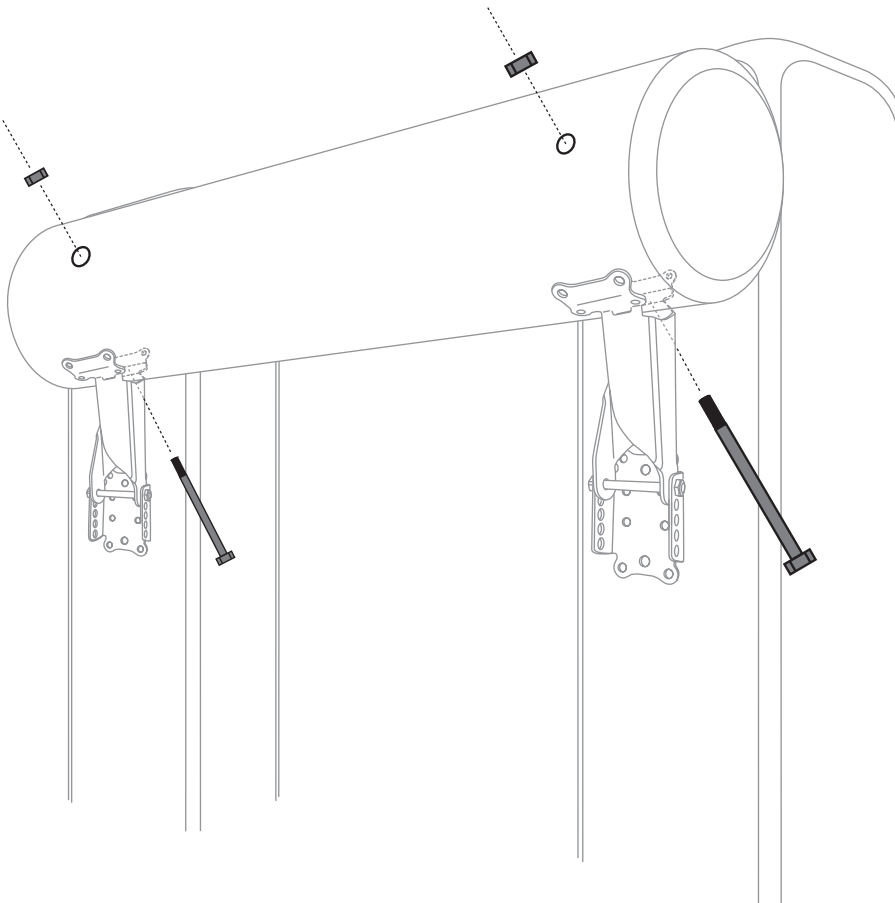
\*alternative



2X	2X
	
not included	not included

CORRECT alignment of the clip

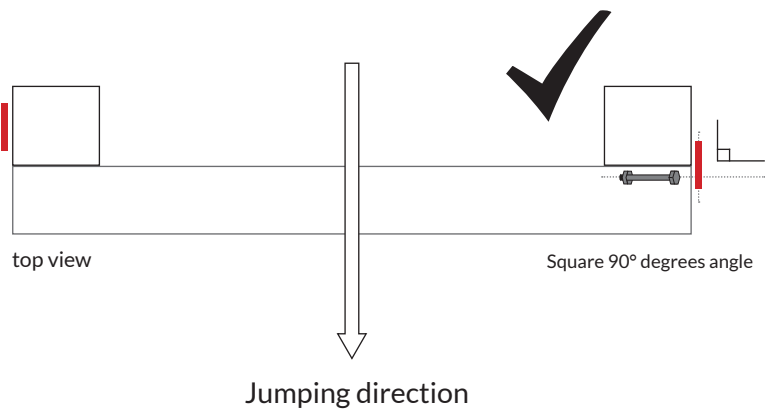

WRONG alignment of the clip

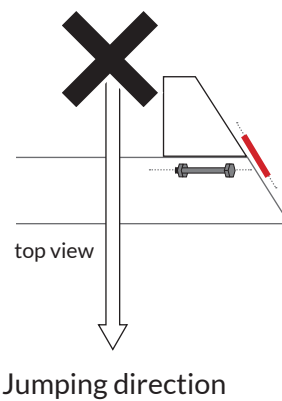

STEP  
**6**

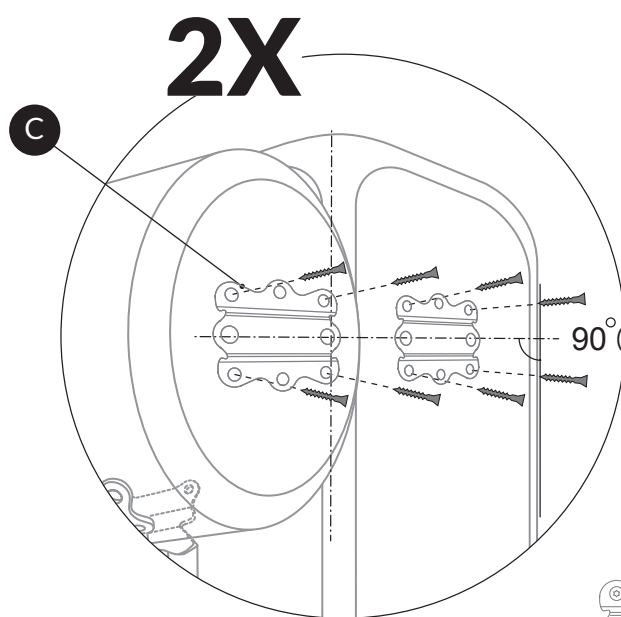
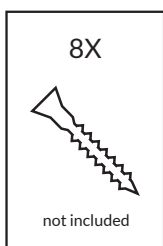

The **C** pieces must be:



**PARALLEL AND HORIZONTALLY LEVELLED**

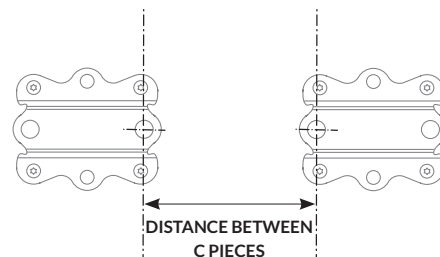

STEP  
**7**

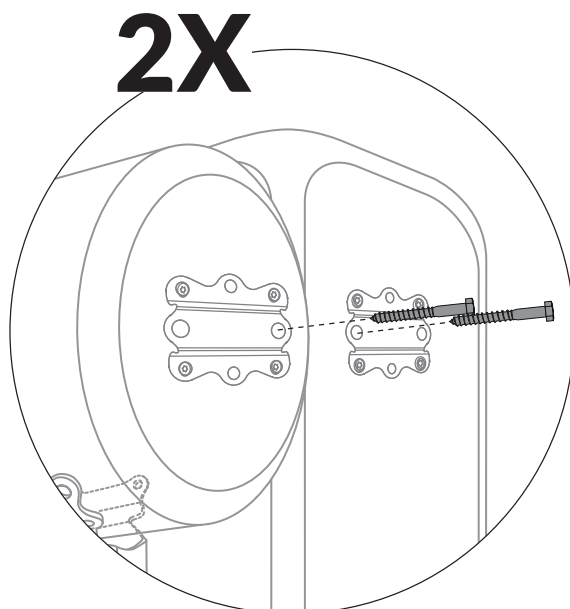
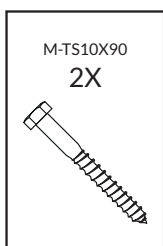

The **C** pieces must be:



**PARALLEL AND HORIZONTALLY LEVELLED**



STEP  
8

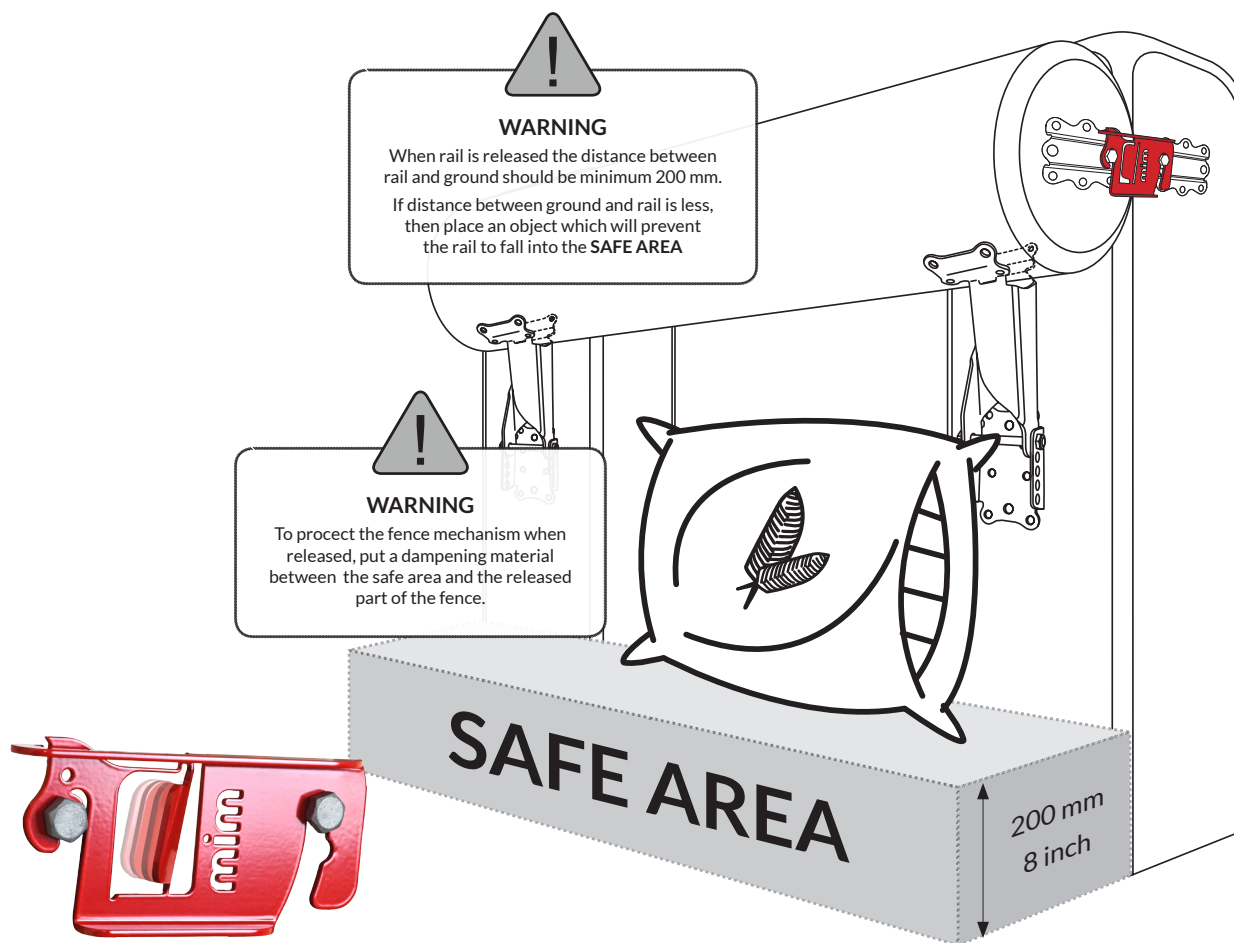
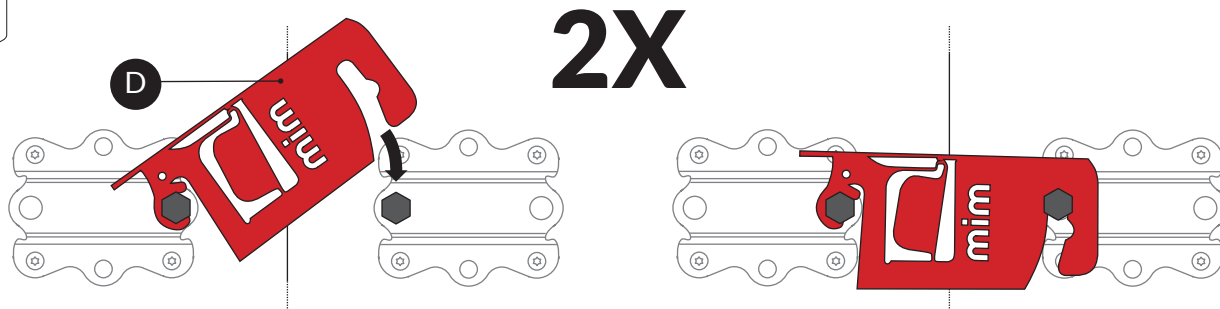

The flag is bent when fatigued.

### The advantages of the MIMclip

The MIMclip (F18C) breaks on impact. The flag is bent when the clip is exposed to fatigue. In both cases the clip must be replaced. The top section is connected to the post with a hinge that makes the fence easy to reconstruct. This saves time, guarantees fair and correct judging for riders and contributes to the overall safety of the sport.

### The advantages of the Post & Rail Kit

1. It has been produced with safety being the first and foremost important factor.
2. Reduces the possibility of rotational falls.
3. FEI approved number FEI10SWE.
4. Controlled movement of fence during release.
5. Reconstruction time is less than 30 seconds.
6. The parts are made of powder coated steel and can be left outside, no maintenance is required.
7. The very highest quality of product from Sweden.