

# Post & Rail Adjustable Kit - 80325

# mimSAFE

mimclip.mimsafe.com

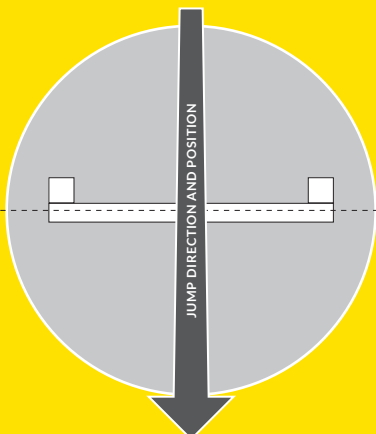
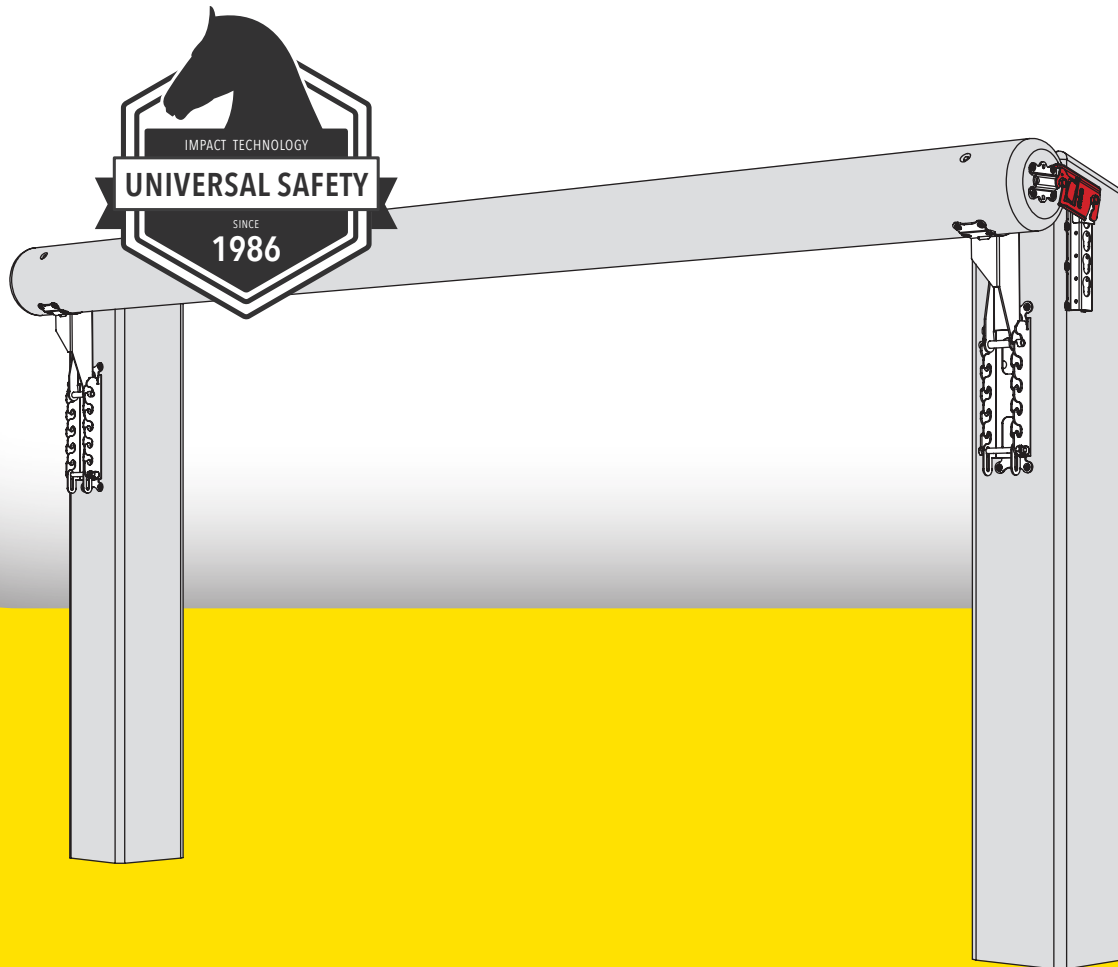

ASSEMBLY AND OPERATION INSTRUCTIONS

## POST & RAIL ADJUSTABLE KIT

MIMCLIP SYSTEM





APPROVED

## INFORMATION ABOUT THE POST & RAIL ADJUSTABLE KIT

The Post & Rail Adjustable Kit has been designed and developed specifically to greatly reduce the risk of rotational falls. The most important element of this kit is that it will not break the fence or

risk injury to the horse if hit vertically. The rail is only released when impacted horizontally by the horse. The risk of a resulting rotational fall is thus reduced.

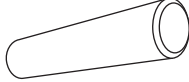
FENCE DIMENSIONS																									
<p>POST</p>  <p>MIN-MAX SIZE</p> <table border="1"> <tr> <td>6 - 10</td> <td>inch</td> </tr> <tr> <td>150 - 250</td> <td>mm</td> </tr> </table>  <p>MIN-MAX SIZE</p> <table border="1"> <tr> <td>6 - 10</td> <td>inch</td> </tr> <tr> <td>150 - 250</td> <td>mm</td> </tr> </table>	6 - 10	inch	150 - 250	mm	6 - 10	inch	150 - 250	mm	<p>RAIL</p>  <p>MIN-MAX DIAMETER</p> <table border="1"> <tr> <td>8 - 12</td> <td>inch</td> </tr> <tr> <td>200 - 300</td> <td>mm</td> </tr> </table> <p>MAXIMUM LENGTH</p> <table border="1"> <tr> <td>13.1</td> <td>ft</td> </tr> <tr> <td>4000</td> <td>mm</td> </tr> </table> <p>MIN-MAX WEIGHT WITH RED CLIP</p> <table border="1"> <tr> <td>110 - 265</td> <td>lb</td> </tr> <tr> <td>50 - 120</td> <td>kg</td> </tr> </table> <p>MIN-MAX WEIGHT WITH YELLOW CLIP</p> <table border="1"> <tr> <td>265 - 297</td> <td>lb</td> </tr> <tr> <td>120 - 180</td> <td>kg</td> </tr> </table> <p>(Yellow clips not included in this assembly kit) order yellow clip spare parts</p>	8 - 12	inch	200 - 300	mm	13.1	ft	4000	mm	110 - 265	lb	50 - 120	kg	265 - 297	lb	120 - 180	kg
6 - 10	inch																								
150 - 250	mm																								
6 - 10	inch																								
150 - 250	mm																								
8 - 12	inch																								
200 - 300	mm																								
13.1	ft																								
4000	mm																								
110 - 265	lb																								
50 - 120	kg																								
265 - 297	lb																								
120 - 180	kg																								



It is essential to follow the recommended dimensions on the fence for the correct function. If the recommended procedure is not correctly followed it may cause the failure of the device.

For your own safety and that of others please note the following step by step advice for correct preparation and installation. It is important that you follow your own health and safety requirements when constructing this kit.

**Ensure that you have all parts of the Post & Rail Adjustable Kit.**

**Be aware of the risk of injury when handling heavy rails, posts and the tools for mounting.**

**WARNING!**



Jumping direction



**IMPORTANT**

The posts must be:  
**PARALLEL,  
& FRONTAL ALIGNED &  
SECURED TO THE GROUND**

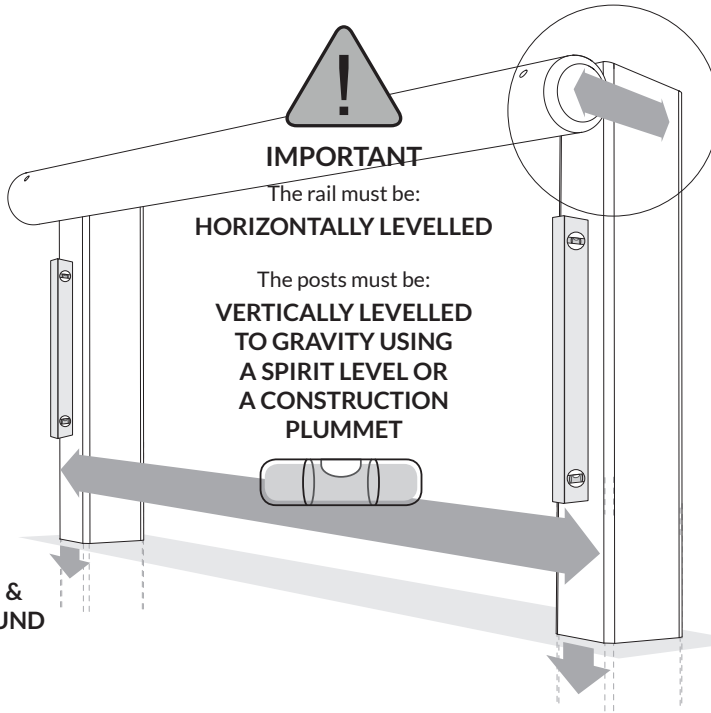

**IMPORTANT**  
The rail must be:  
**HORIZONTALLY LEVELLED**

The posts must be:  
**VERTICALLY LEVELLED  
TO GRAVITY USING  
A SPIRIT LEVEL OR  
A CONSTRUCTION  
PLUMMET**

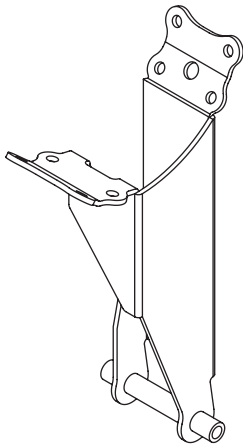
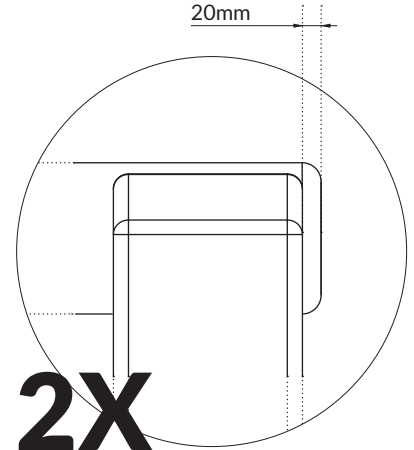

**A** FS65B  
Part no 2x

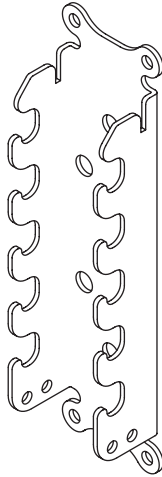

**B** F65E  
Part no 2x

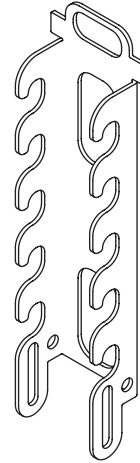

**C** F65F  
Part no 2x

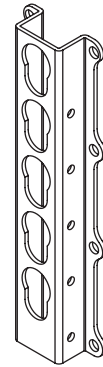

**D** F65H  
Part no 2x

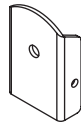







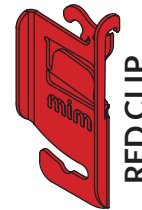

**E** F65G  
Part no 2x



**F** F70A  
Part no 2x



**G** F18C  
Part no 6x

M-SM6x70 2X 	M-MM6Ny 2X 	M-SM10x30 2X 	M-MM10Ny 2X 	M-BR11x22x2s 4X 	M-BR11x28x2s 2X 	M-SM10x100 2X 	M-MM10Ny 4X 	M-TS10X90 2X 
---	--	--	---	---	---	--	---	--

STEP  
**1**

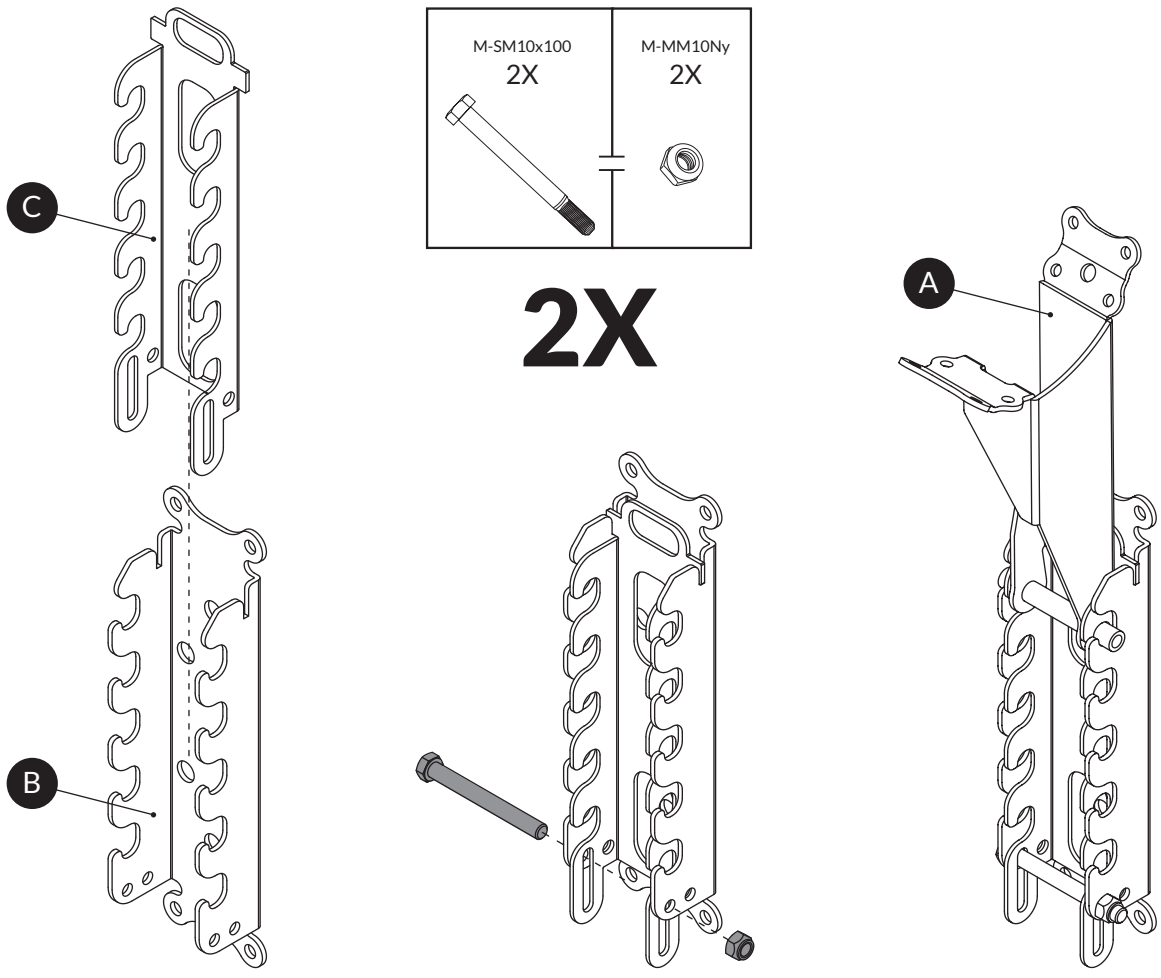

STEP  
**2**

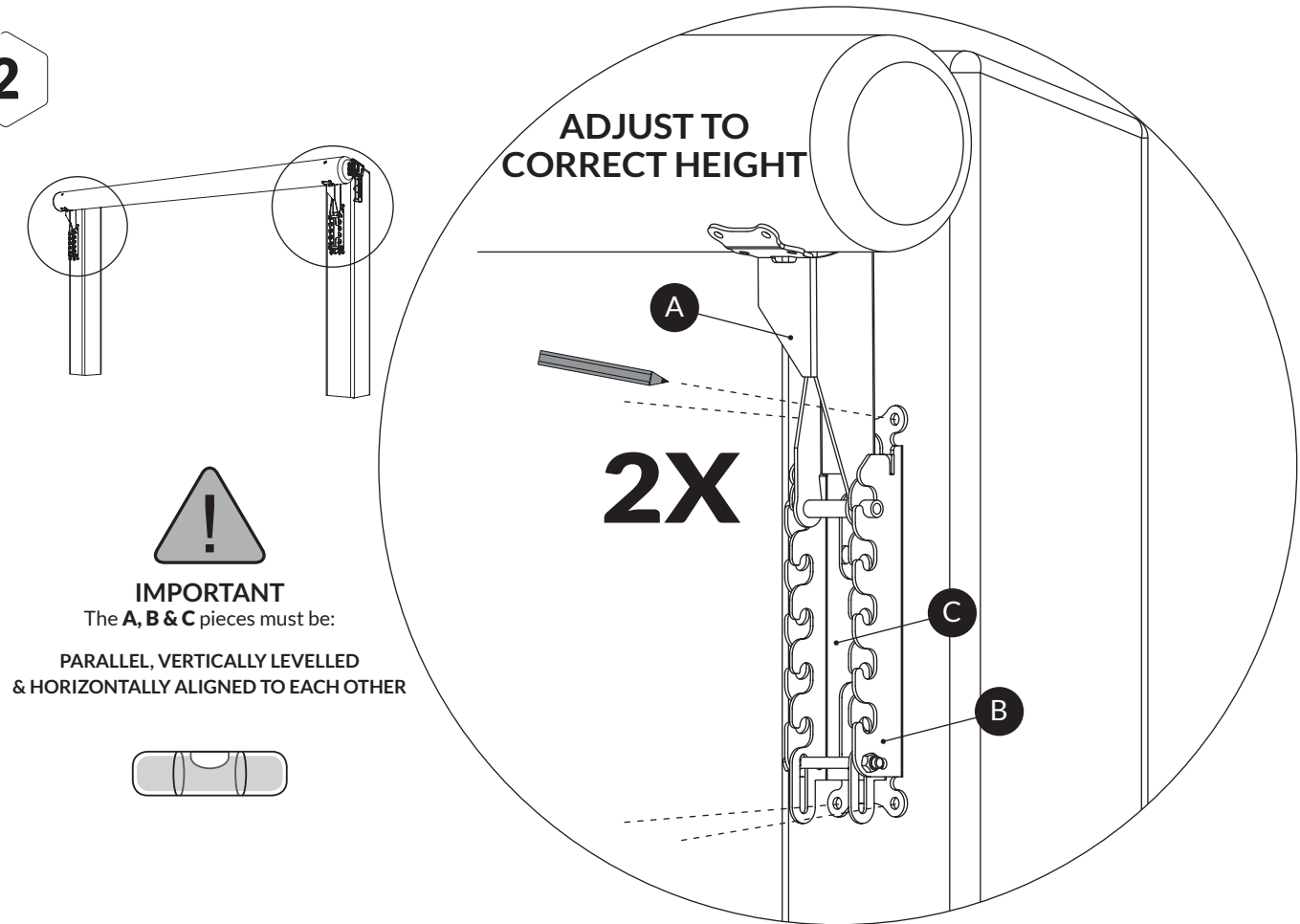

STEP  
**3**

**2X**

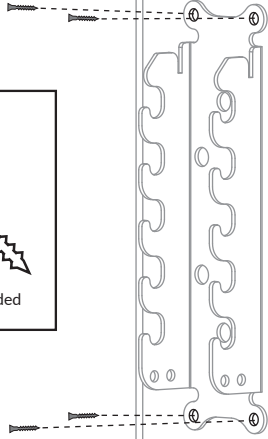
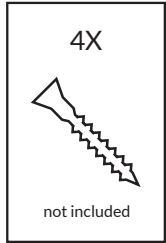

STEP  
**3\***

\*alternative

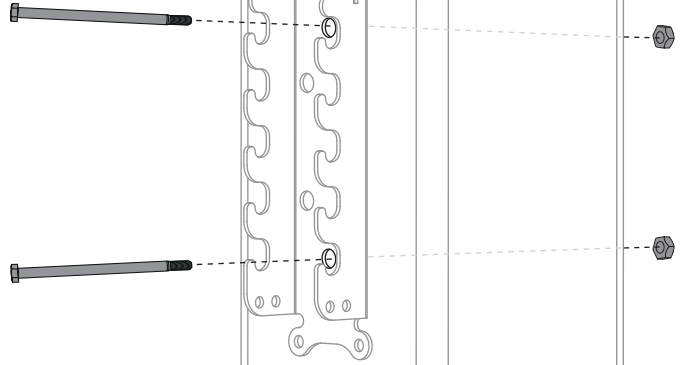
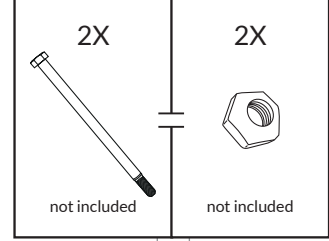

**2X**

STEP  
**4**

**2X**

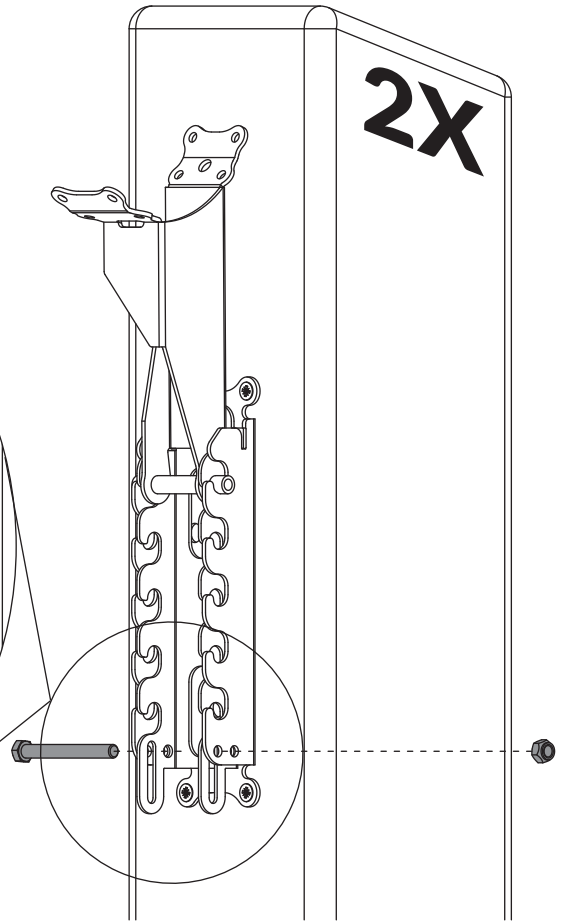
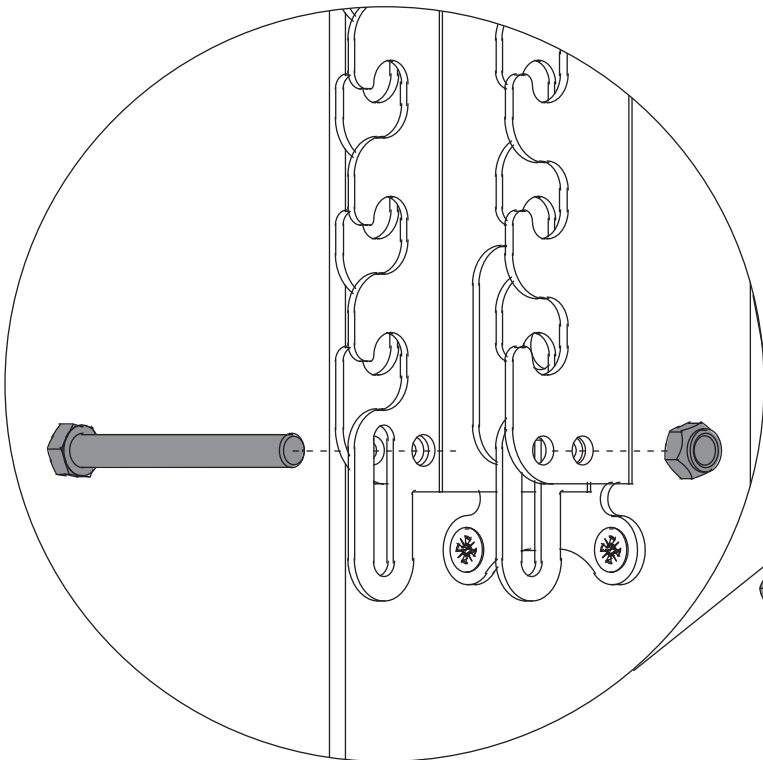

STEP  
**5**

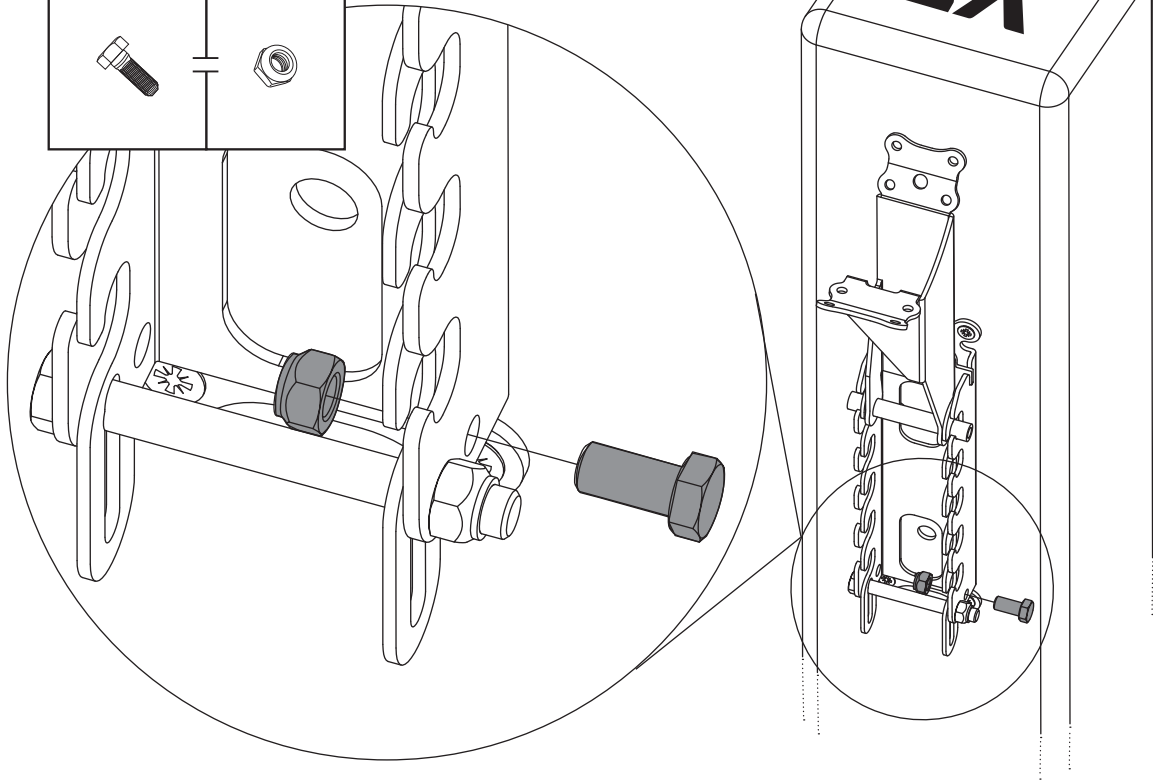
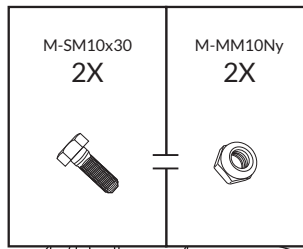

STEP  
**6**

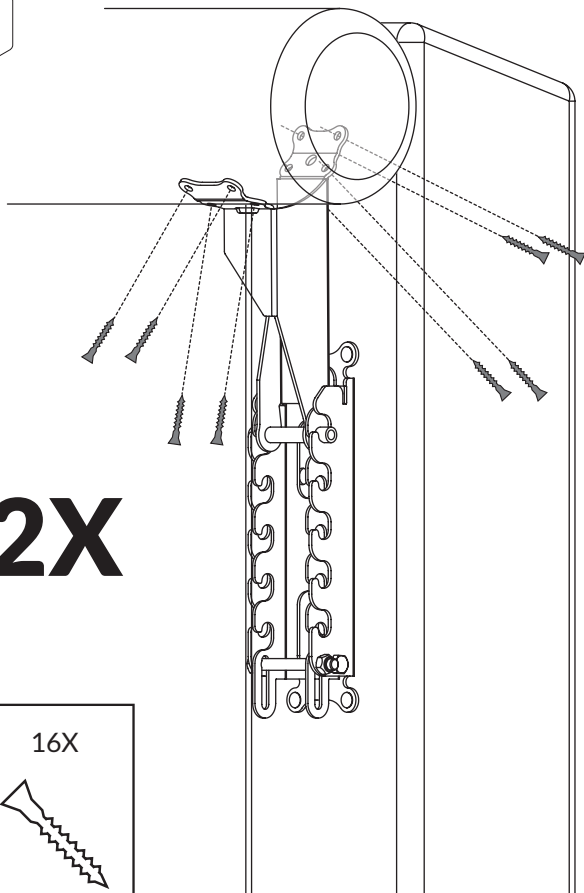

**2X**

16X



not included

STEP  
**6\***

\*alternative

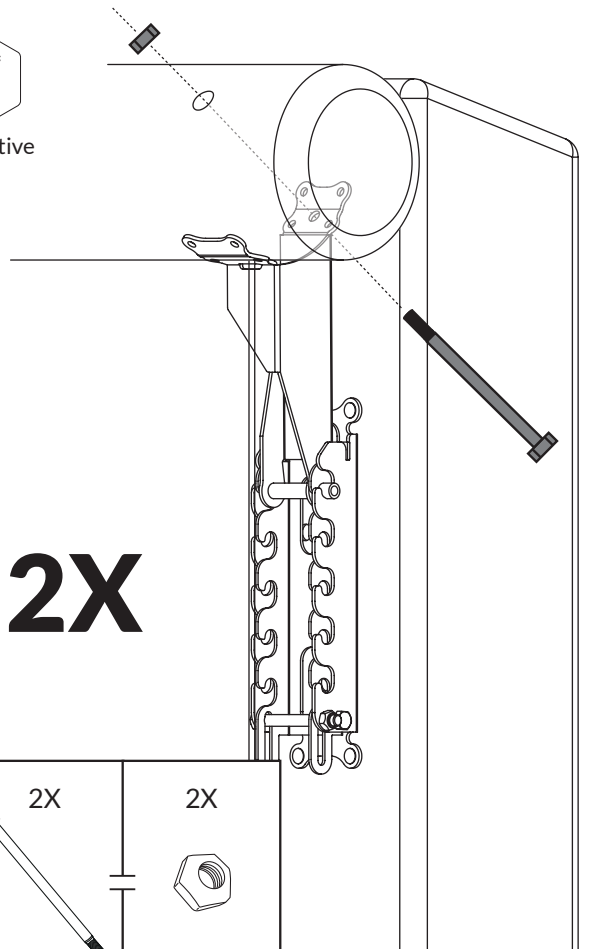

**2X**

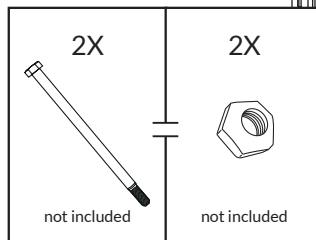

STEP  
**7**

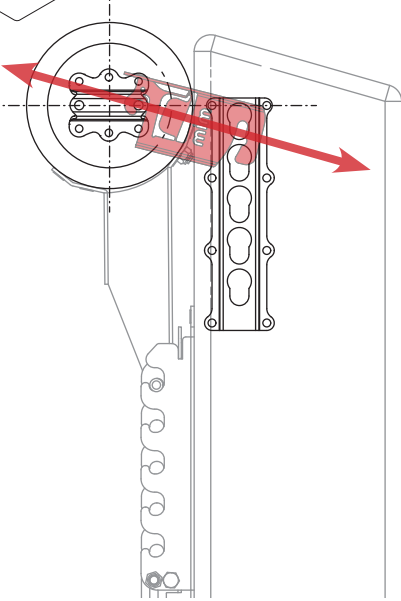

**2X**

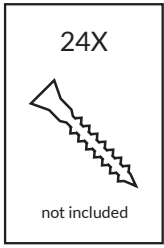

**F**

**D**

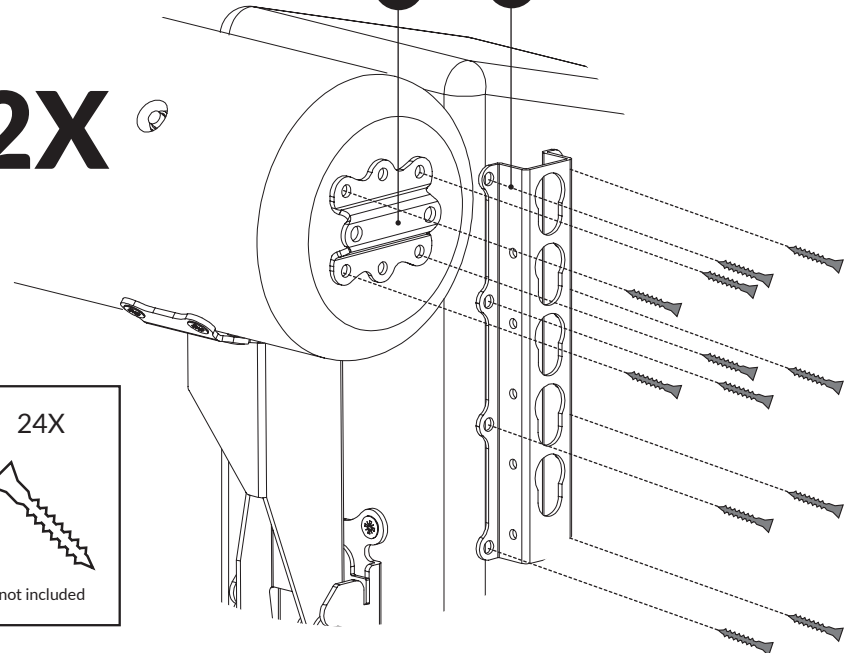

STEP  
**8**



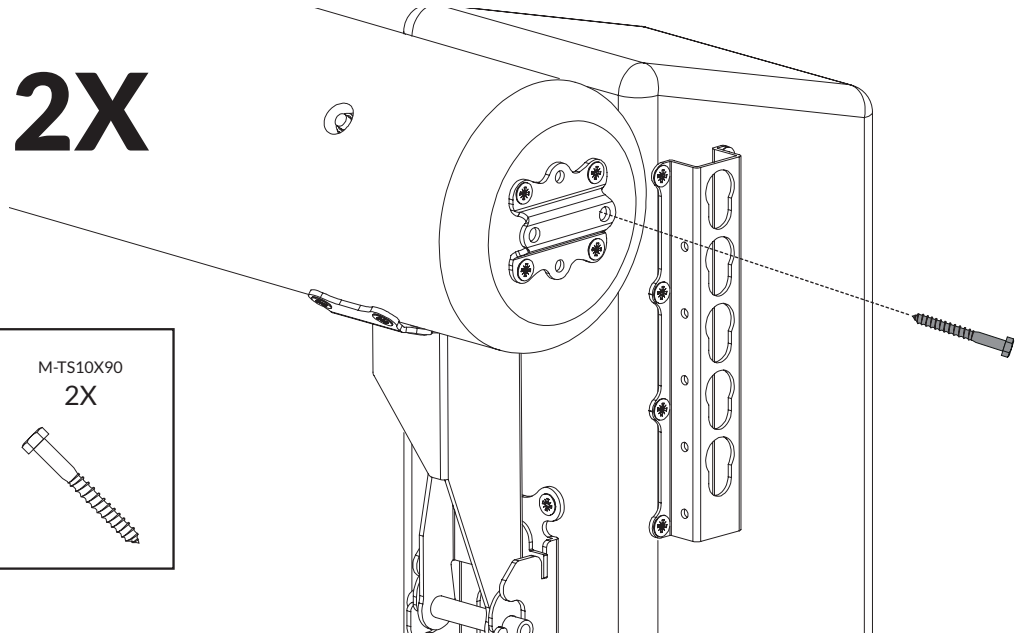
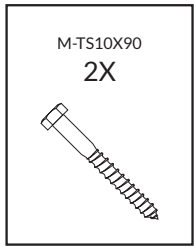

**2X**

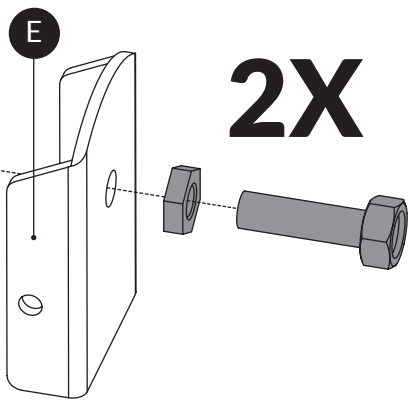

STEP  
**9**

**2X**



M-SM10x30 2X 	M-BR11x28x2s 2X 	
M-MM10Ny 2X 	M-BR11x22x2s 4X 	M-MM10Ny 2X 

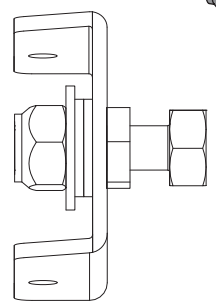

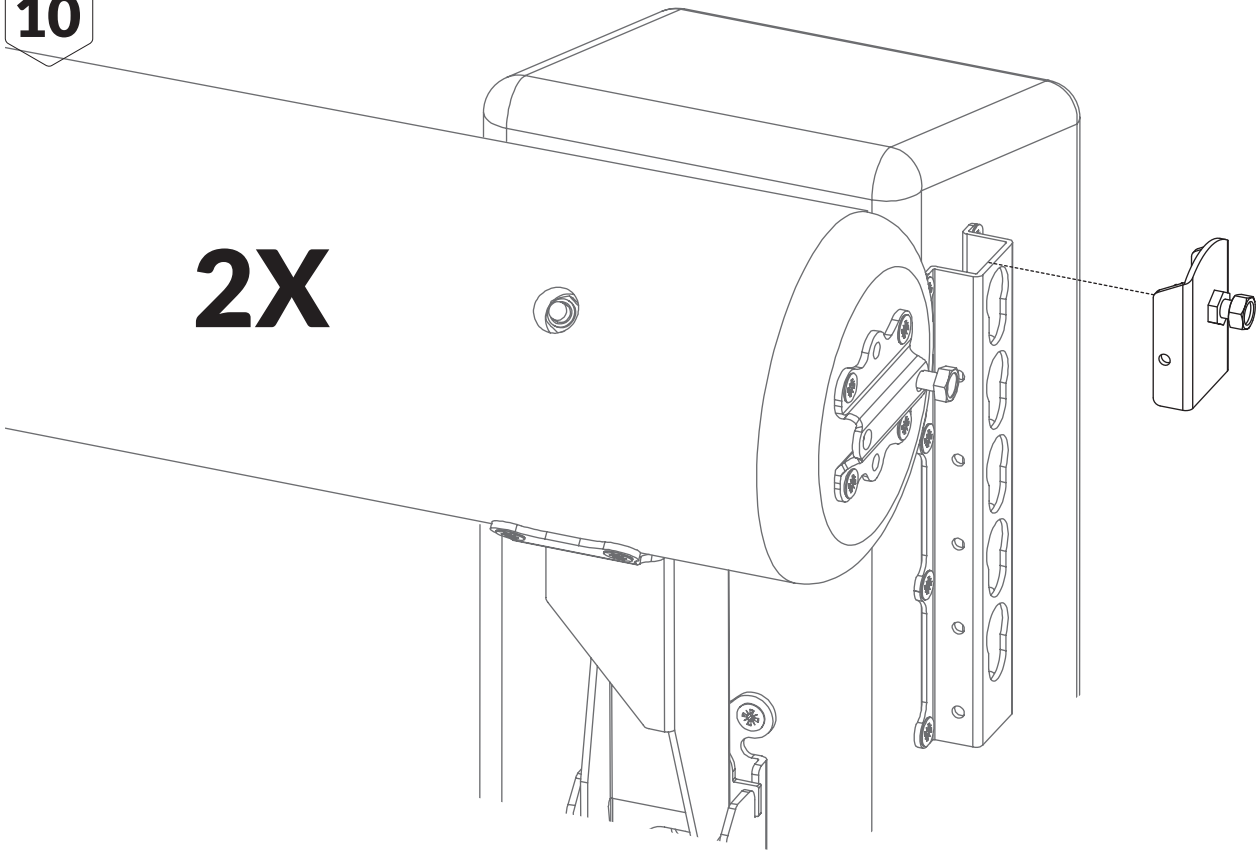

STEP  
**10**

**2X**



STEP  
**11**

**2X**

M-SM6x70 2X	M-MM6Ny 2X
	

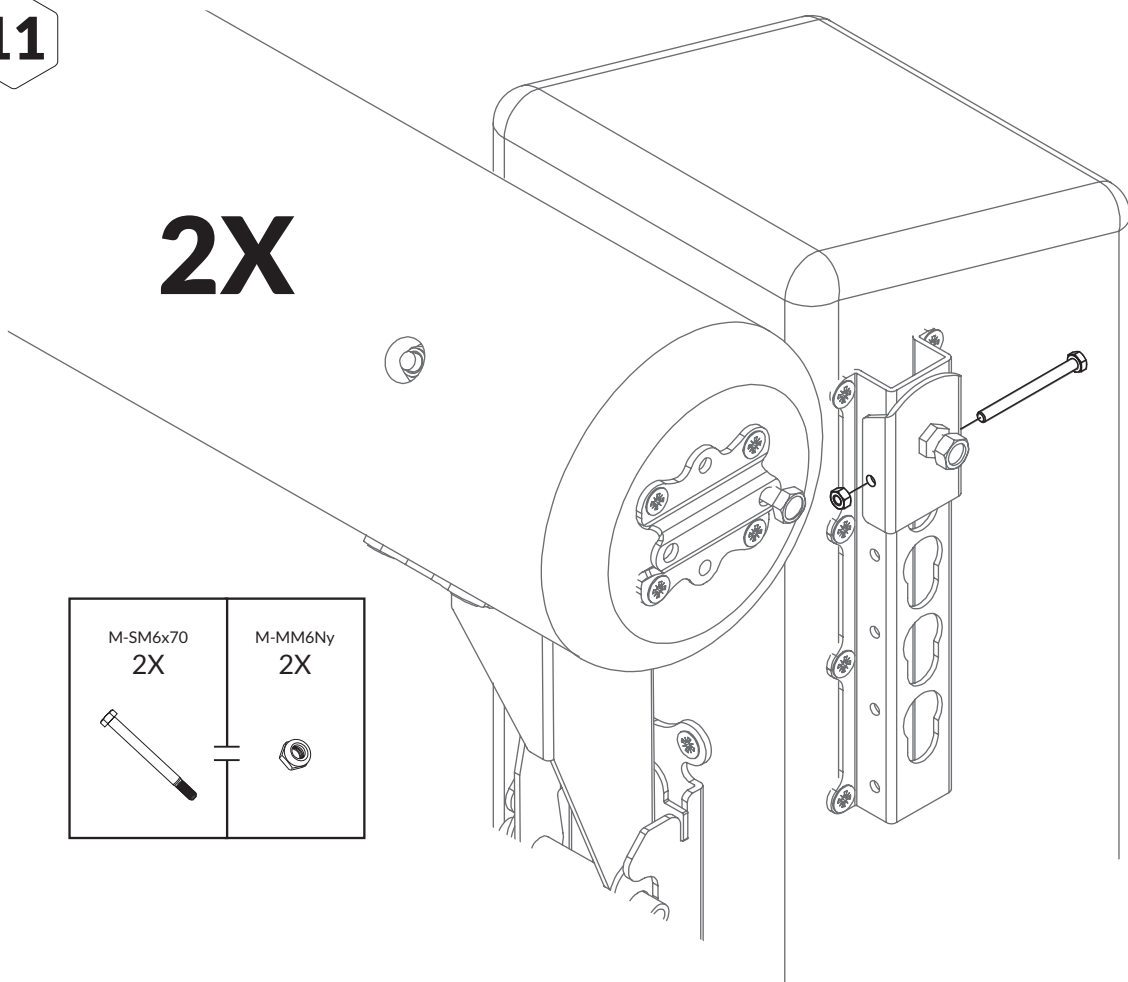



STEP  
**12**

**2X**

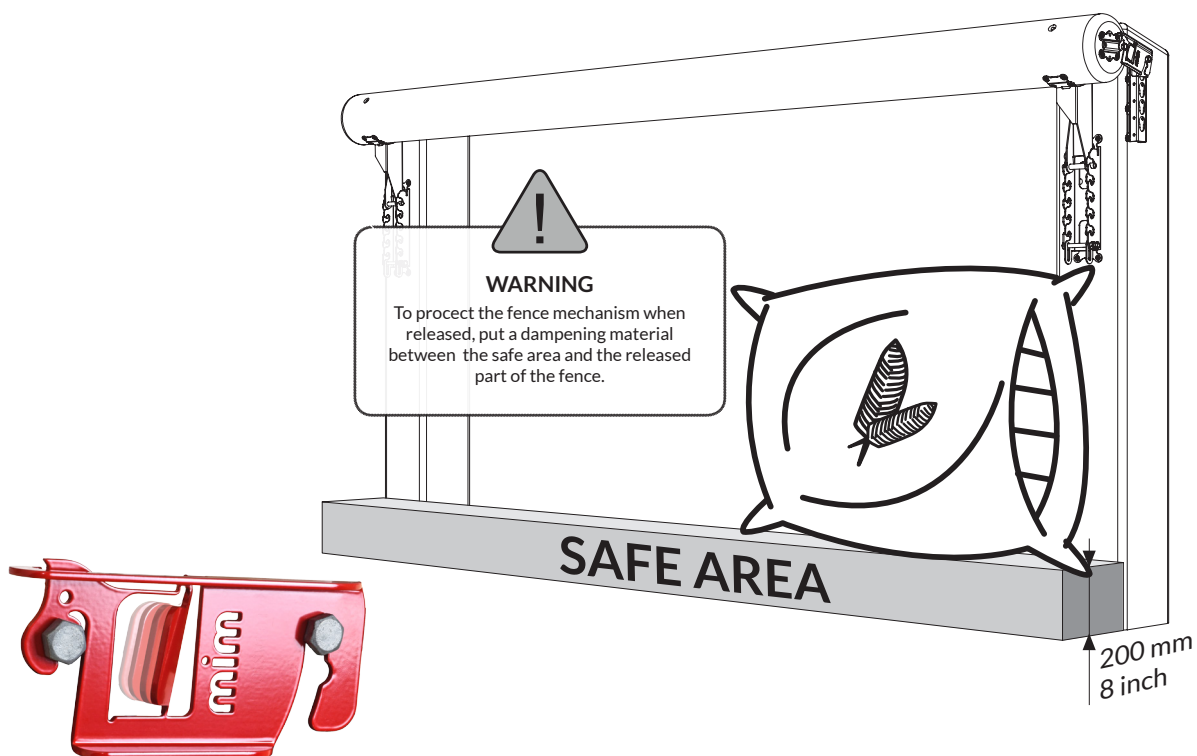
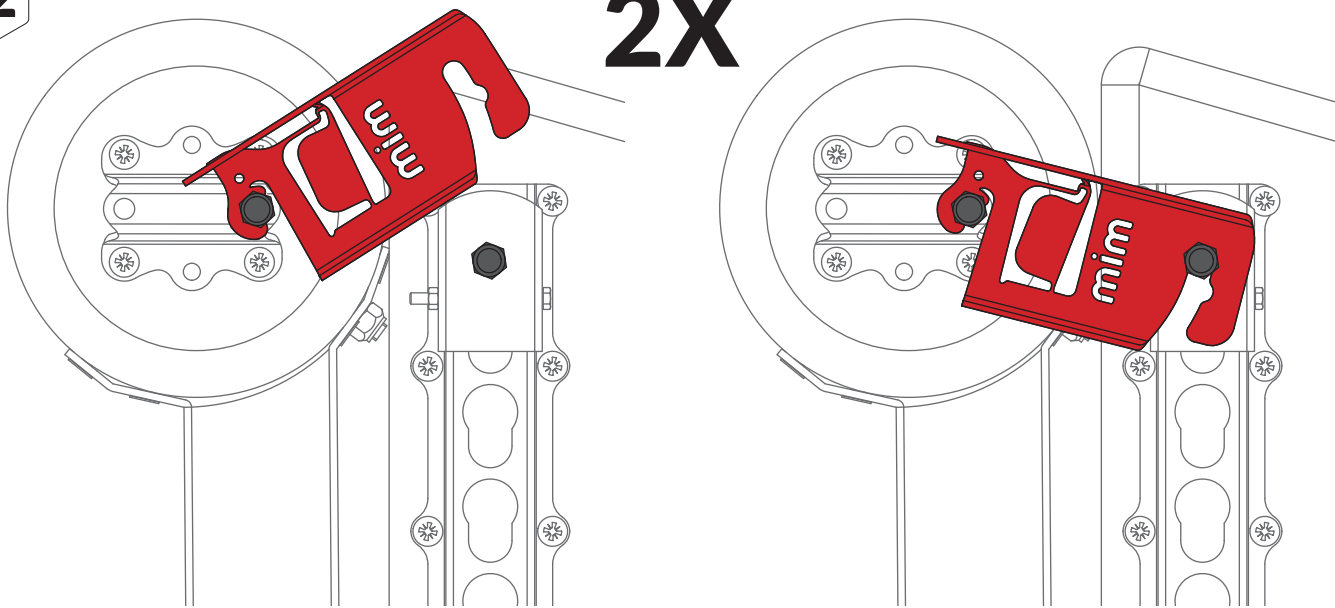

The flag is bent when fatigued.

### The advantages of the MIMclip

The MIMclip (F18C) breaks on impact. The flag is bent when the clip is exposed to fatigue. In both cases the clip must be replaced. The top section is connected to the post with a hinge that makes the fence easy to reconstruct. This saves time, guarantees fair and correct judging for riders and contributes to the overall safety of the sport.

### The advantages of the Post & Rail Adjustable Kit

1. It has been produced with safety being the first and foremost important factor.
2. Reduces the possibility of rotational falls.
3. FEI approved number FEI11SWE.
4. Controlled movement of fence during release.
5. Reconstruction time is less than 30 seconds.
6. The parts are made of powder coated steel and can be left outside, no maintenance is required.
7. The very highest quality of product from Sweden.