

Post & Rail Kit - 80321

mimSAFE

mimclip.mimsafe.com

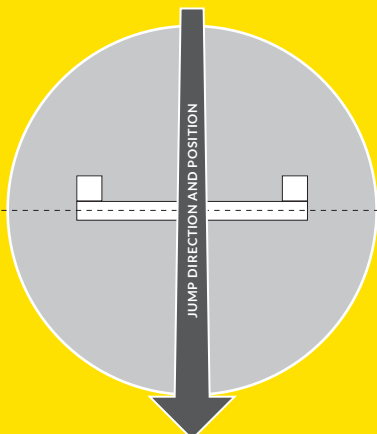
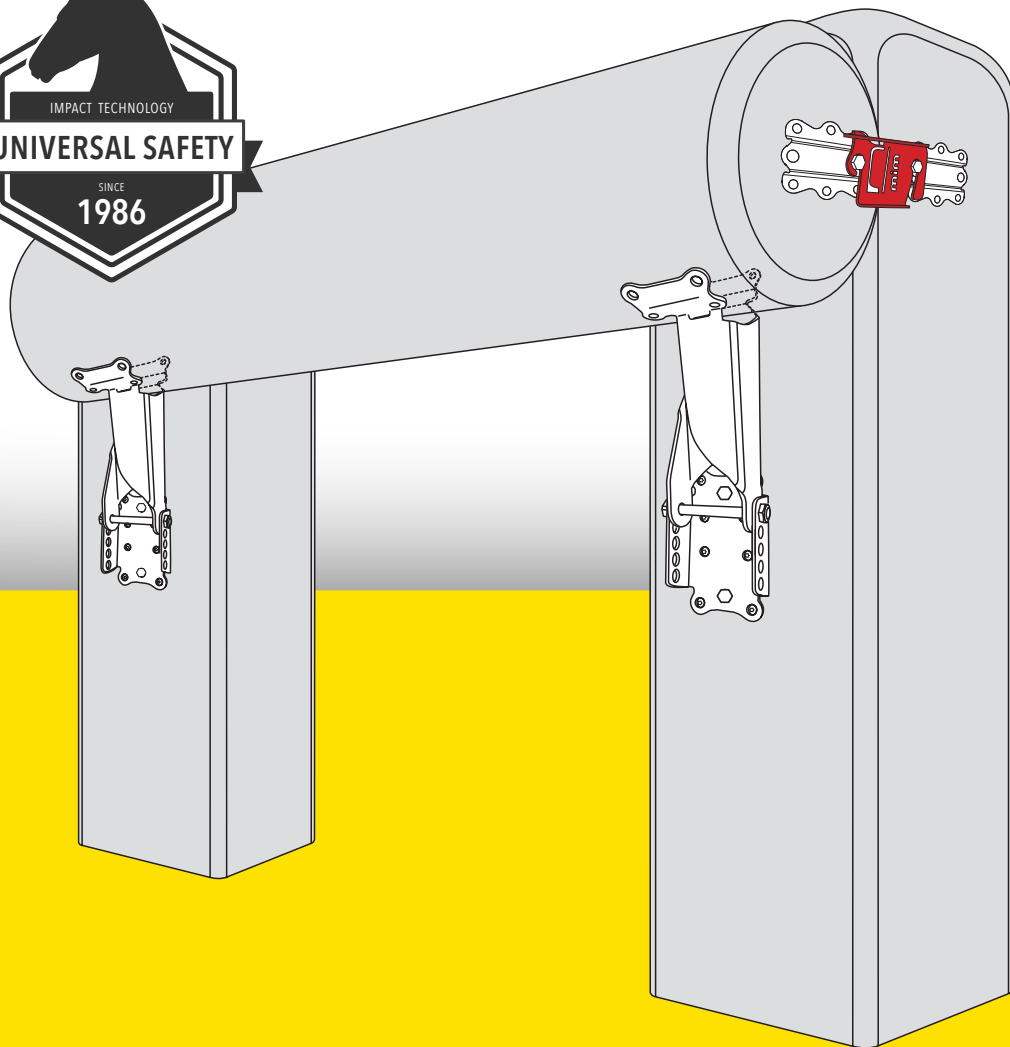

ASSEMBLY AND OPERATION INSTRUCTIONS

POST & RAIL KIT

MIMCLIP SYSTEM





APPROVED

INFORMATION ABOUT THE POST & RAIL KIT

The Post & Rail Kit has been designed and developed specifically to greatly reduce the risk of rotational falls. The most important element of this kit is that it will not break the fence or

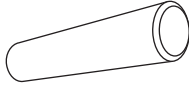
risk injury to the horse if hit vertically. The rail is only released when impacted horizontally by the horse. The risk of a resulting rotational fall is thus reduced.

FENCE DIMENSIONS									
POST 	RAIL 								
MIN-MAX SIZE <table border="1"> <tr> <td>6 - 10</td> <td>inch</td> </tr> <tr> <td>150 - 250</td> <td>mm</td> </tr> </table>	6 - 10	inch	150 - 250	mm	MIN-MAX DIAMETER <table border="1"> <tr> <td>8 - 12</td> <td>inch</td> </tr> <tr> <td>200 - 300</td> <td>mm</td> </tr> </table>	8 - 12	inch	200 - 300	mm
6 - 10	inch								
150 - 250	mm								
8 - 12	inch								
200 - 300	mm								
	MAXIMUM LENGTH <table border="1"> <tr> <td>13.1</td> <td>ft</td> </tr> <tr> <td>4000</td> <td>mm</td> </tr> </table>	13.1	ft	4000	mm				
13.1	ft								
4000	mm								
MIN-MAX SIZE <table border="1"> <tr> <td>6 - 10</td> <td>inch</td> </tr> <tr> <td>150 - 250</td> <td>mm</td> </tr> </table>	6 - 10	inch	150 - 250	mm	MIN-MAX WEIGHT WITH RED CLIP <table border="1"> <tr> <td>110 - 265</td> <td>lb</td> </tr> <tr> <td>50 - 120</td> <td>kg</td> </tr> </table>	110 - 265	lb	50 - 120	kg
6 - 10	inch								
150 - 250	mm								
110 - 265	lb								
50 - 120	kg								
	MIN-MAX WEIGHT WITH YELLOW CLIP <table border="1"> <tr> <td>265 - 330</td> <td>lb</td> </tr> <tr> <td>120 - 150</td> <td>kg</td> </tr> </table>	265 - 330	lb	120 - 150	kg				
265 - 330	lb								
120 - 150	kg								
	<small>(Yellow clips not included in this assembly kit) order yellow clip spare parts</small>								



It is essential to follow the recommended dimensions on the fence for the correct function. If the recommended procedure is not correctly followed it may cause the failure of the device.

For your own safety and that of others please note the following step by step advice for correct preparation and installation. It is important that you follow your own health and safety requirements when constructing this kit.

Ensure that you have all parts of the Post & Rail Kit.

Be aware of the risk of injury when handling heavy rails, posts and the tools for mounting.

WARNING!



Jumping direction

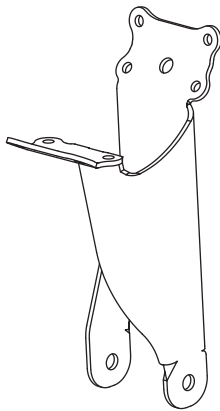
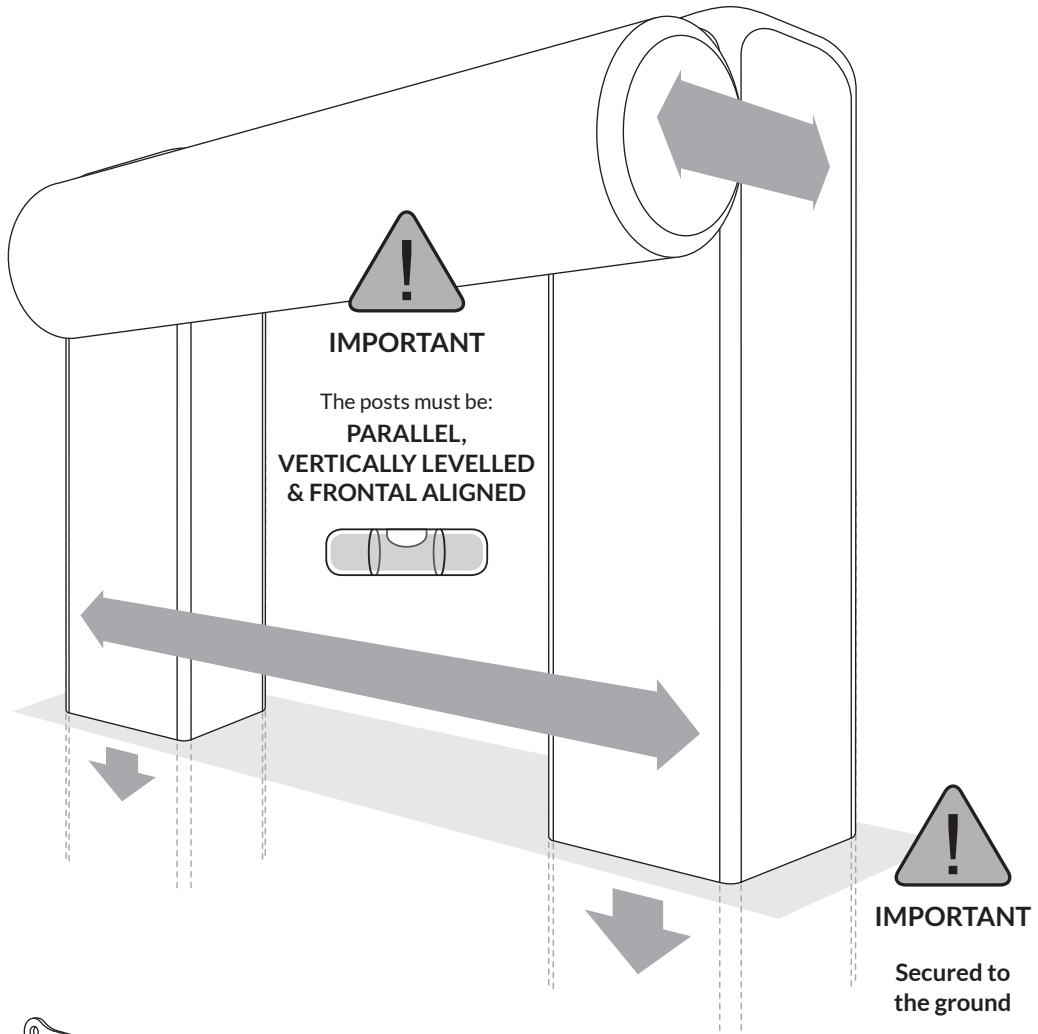

A F65 2x
Part no

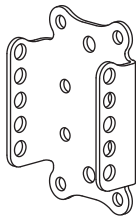

B F64A5 2x
Part no

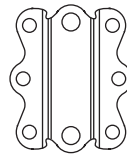

C F70A 4x
Part no





D F18C 6x
Part no

<p>M-SM12x120 2X</p>	<p>M-BR12x22x2s 2X</p>	<p>M-MM12Ny 2X</p>	<p>M-TS10X90 4X</p>	<p>POST 2X</p> <p>not included</p>	<p>RAIL 1X</p> <p>not included</p>
--------------------------	----------------------------	------------------------	-------------------------	--	--

STEP
1

2X

M-SM12x120 2X 	M-BR12x22x2s 2X 	M-MM12Ny 2X 
---	---	---

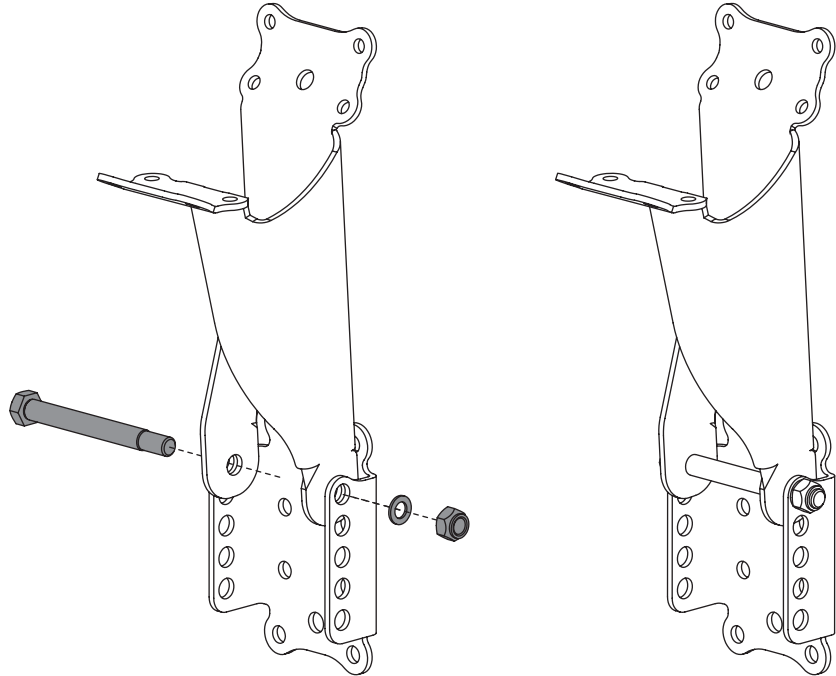
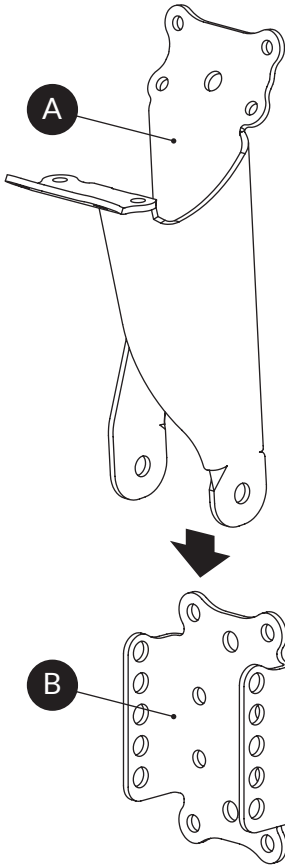

STEP
2

2X

**ADJUST TO
CORRECT HEIGHT**

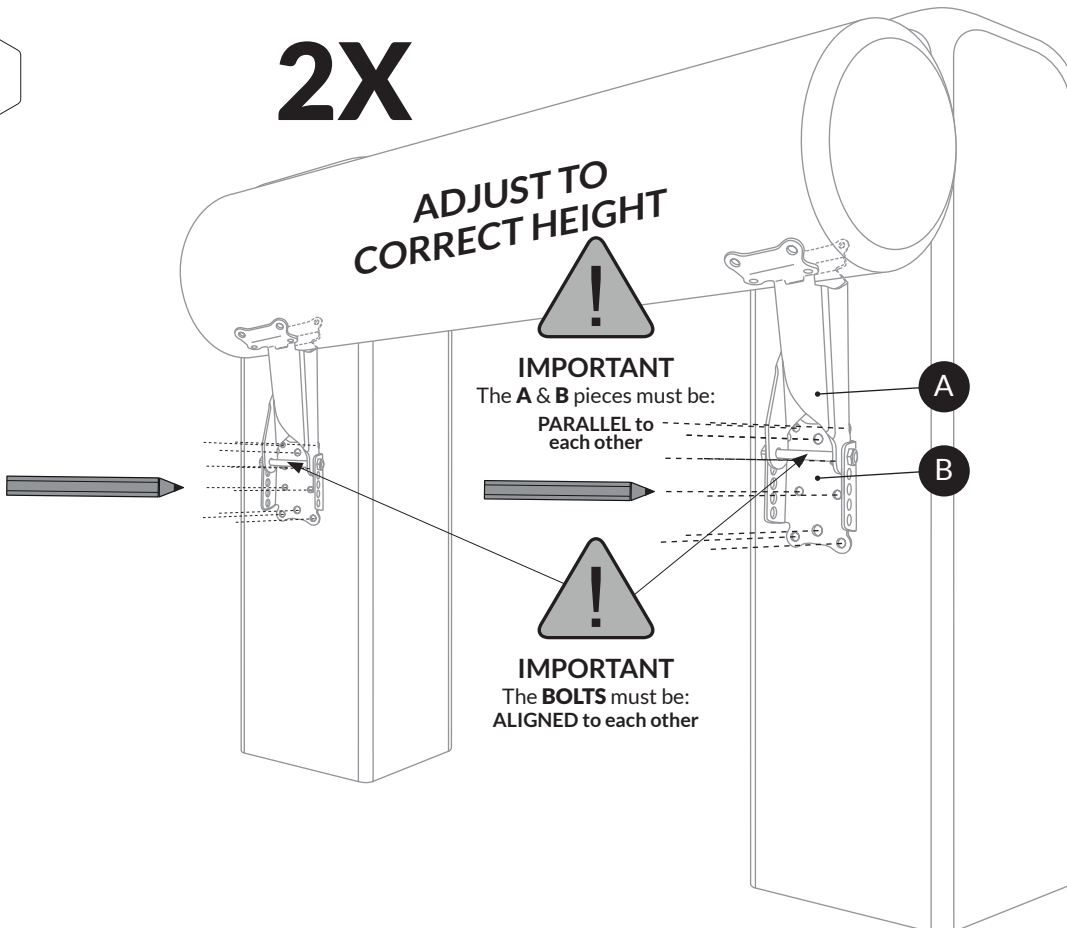

IMPORTANT
The **A & B** pieces must be:
PARALLEL to
each other



IMPORTANT
The **BOLTS** must be:
ALIGNED to each other

STEP
3

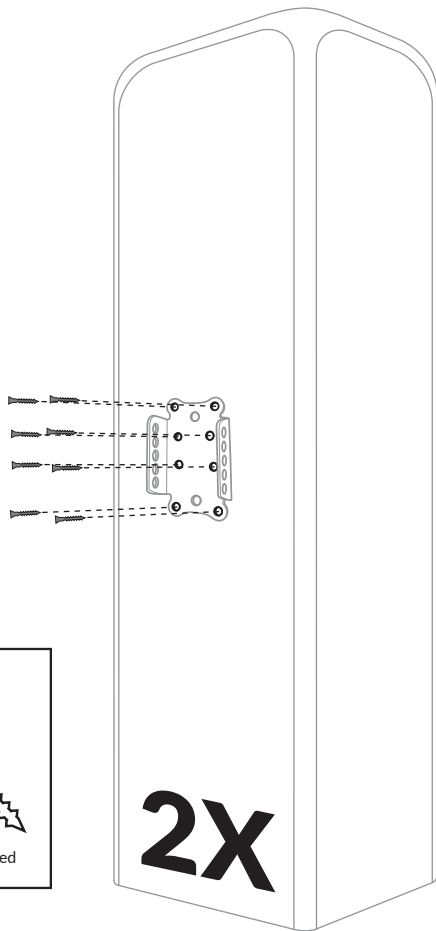

STEP
3*

*alternative

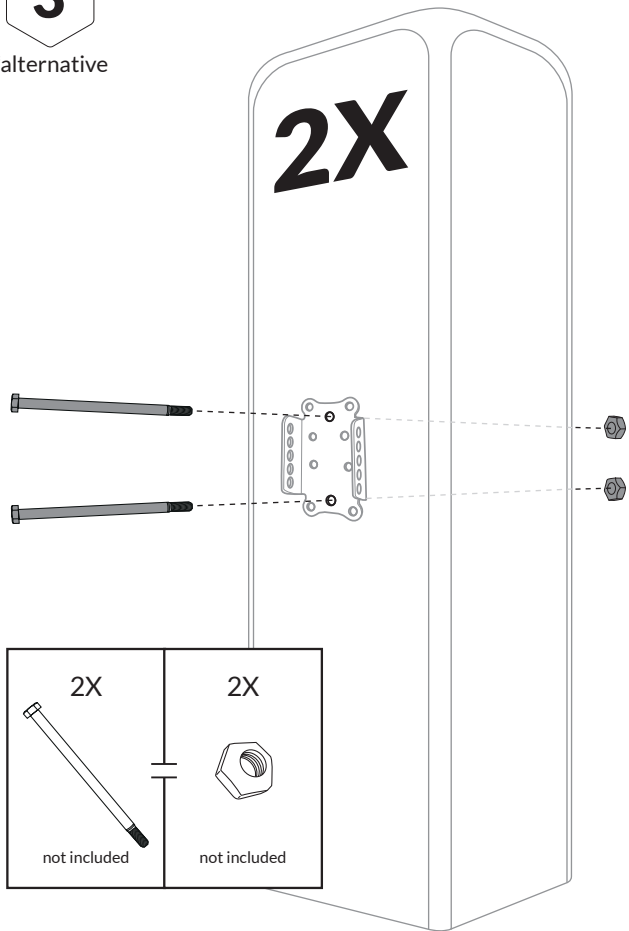

STEP
4

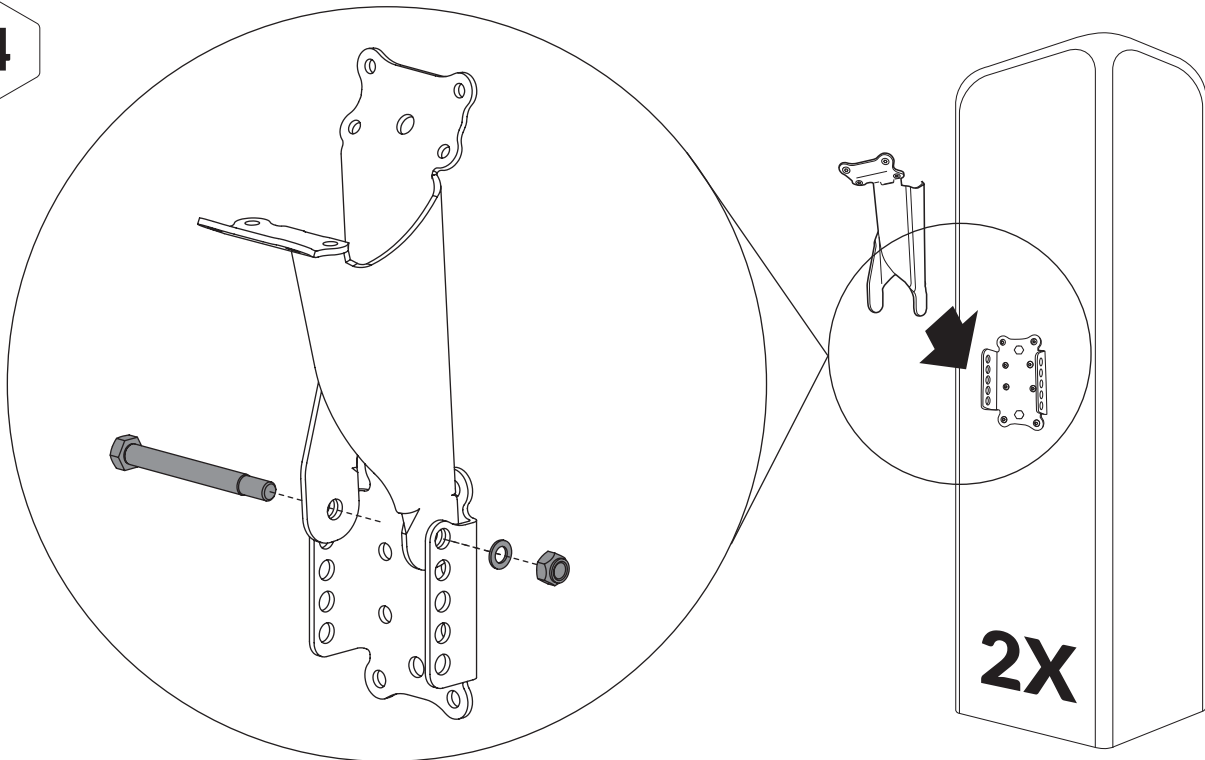

STEP
5

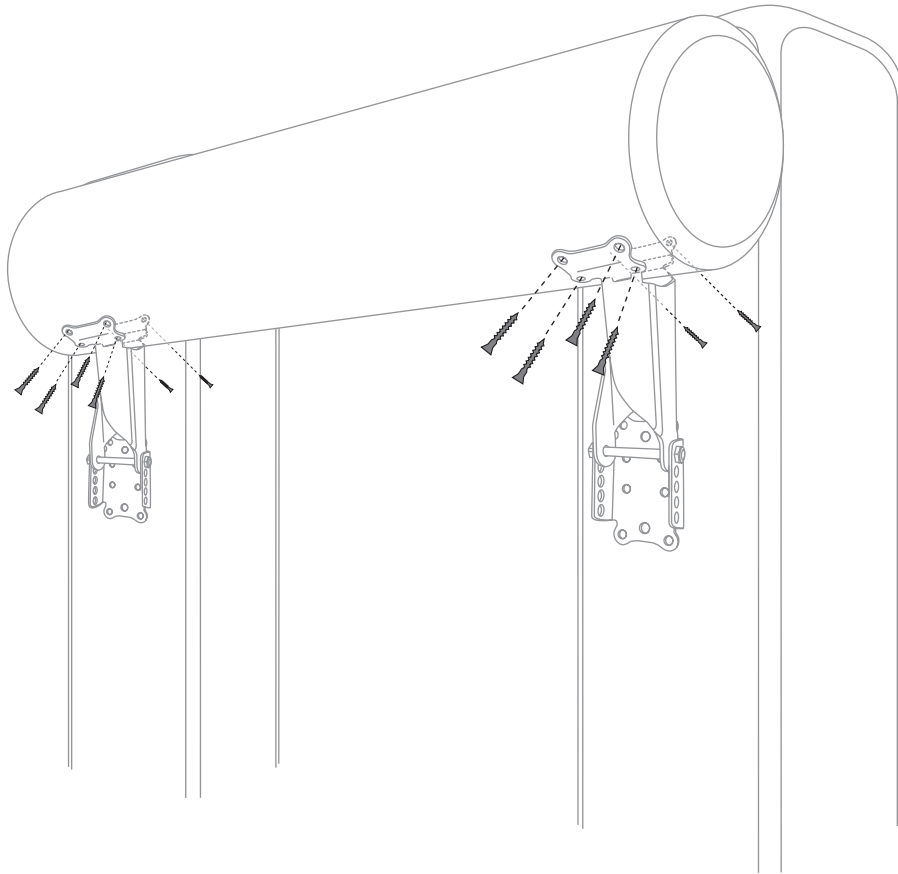

12X

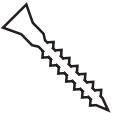



not included

STEP
5*

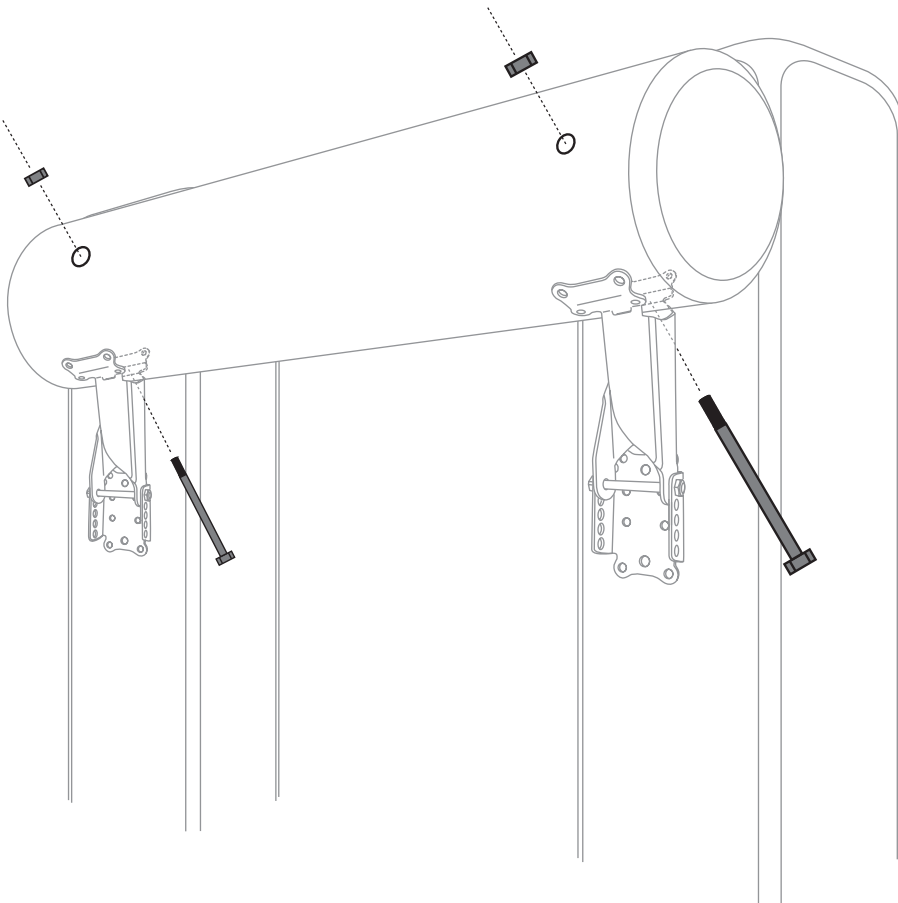
*alternative



2X	2X
	
not included	not included

CORRECT alignment of the clip

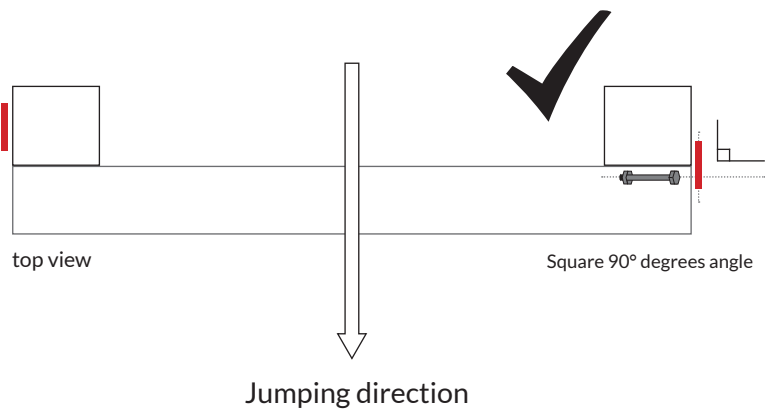

WRONG alignment of the clip

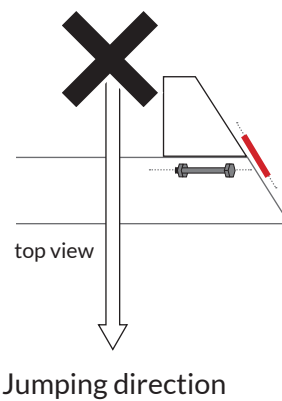

STEP
6

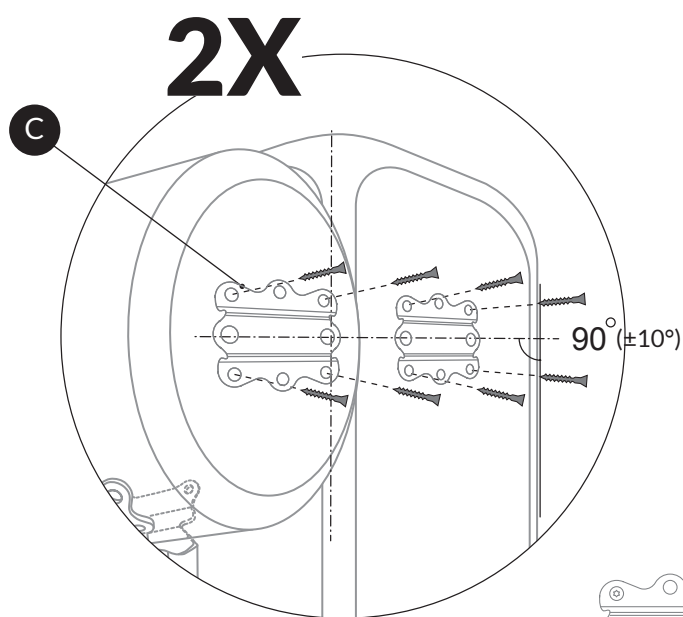
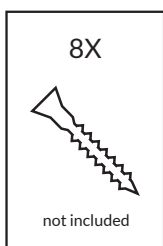

The **C** pieces must be:



PARALLEL AND
HORIZONTALLY LEVELLED

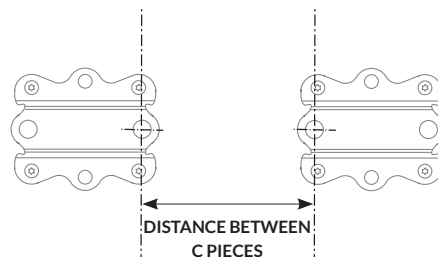

STEP
7

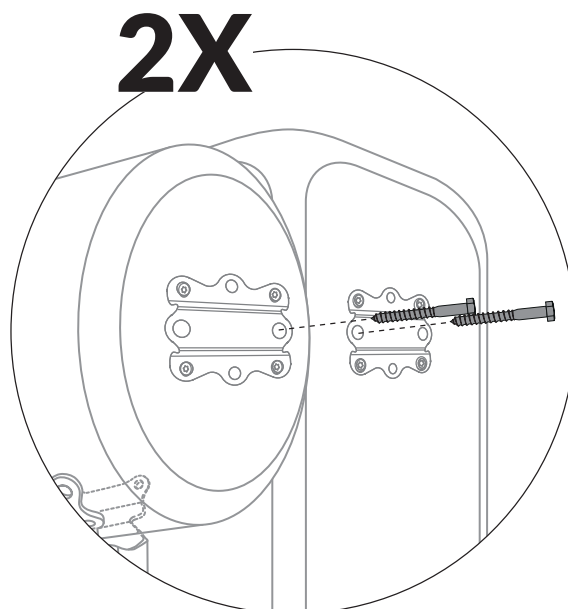
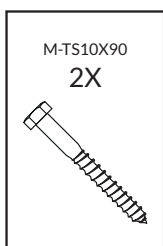

The **C** pieces must be:



PARALLEL AND
HORIZONTALLY LEVELLED



STEP
8

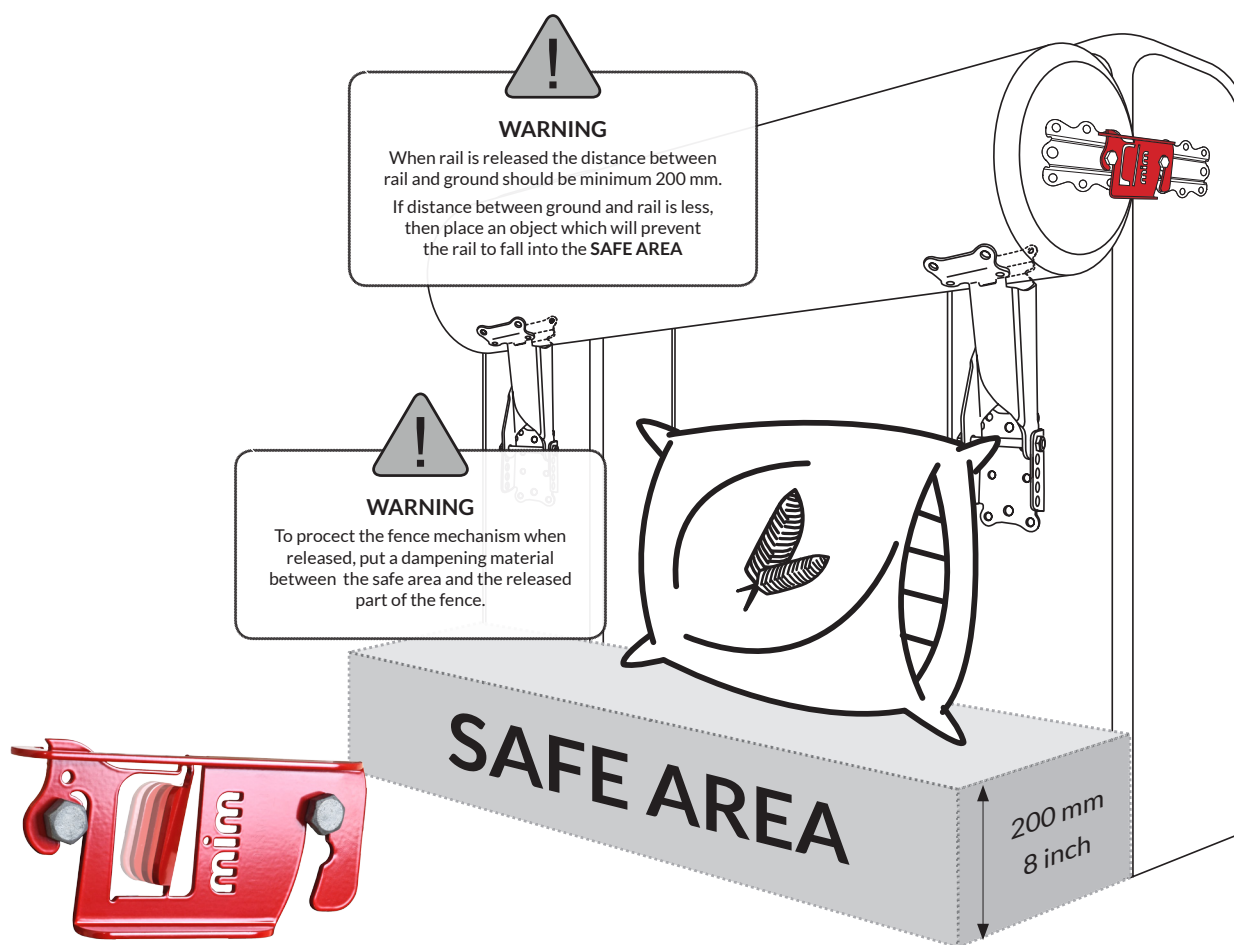
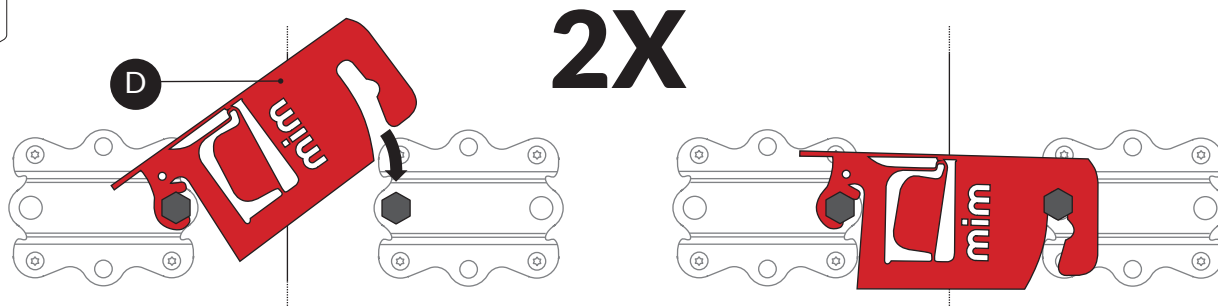

The flag is bent when fatigued.

The advantages of the MIMclip

The MIMclip (F18C) breaks on impact. The flag is bent when the clip is exposed to fatigue. In both cases the clip must be replaced. The top section is connected to the post with a hinge that makes the fence easy to reconstruct. This saves time, guarantees fair and correct judging for riders and contributes to the overall safety of the sport.

The advantages of the Post & Rail Kit

1. It has been produced with safety being the first and foremost important factor.
2. Reduces the possibility of rotational falls.
3. FEI approved number FEI10SWE.
4. Controlled movement of fence during release.
5. Reconstruction time is less than 30 seconds.
6. The parts are made of powder coated steel and can be left outside, no maintenance is required.
7. The very highest quality of product from Sweden.